



FACF 3500[®]
Fully Automatic Capsule Filler
User Manual



We don't just sell machines—
we provide service.



Copyright Notice

Copyright © 2024 by LFA Machines

All rights reserved. No part of this publication may be reproduced, distributed, or transmitted in any form or by any means, including photocopying, recording, or other electronic or mechanical methods, without the prior written permission of the publisher, except in the case of brief quotations embodied in critical reviews and certain other non-commercial uses permitted by copyright law.

Important Safety Information

READ THIS BEFORE OPERATING MACHINE

Intended Use

The intended use of this machine is to fill empty capsules with dry raw materials.

Potential misuse of this machine includes:

- Using any capsules that deviate from the standard two-piece design.
- Using softgel capsules.
- Using powders that could explode under pressure.
- Using wet or damp material.

Personal Protection

For personal protection while transporting the FACP 3500[®], abide by these actions:

- Use a pallet jack to lift the machine.
- Wear steel toe boots to prevent foot injury.
- Wear heavy duty grip gloves to ensure firm grasp on machine.
- Wear back support belt to prevent injury if needed.

For personal protection while operating the FACP 3500[®], abide by these actions:

- Avoid wearing loose jewelry to prevent machine entanglement.
- Contain long hair to prevent machine entanglement.
- Wear safety goggles.
- Wear disposable latex/rubber gloves.
- Wear a hairnet (food grade products only).
- Wear a beard net if needed (food grade products only).

General Hazards

In the case of an emergency during operation, immediately push the Emergency Stop button.

- Do not allow powder to collect at the Turret and Tamping Station.
- Be aware of risk of entanglement and pinch point due to moving parts.
- Do not operate in a wet environment or with wet hands due to risk of electrical shock or burn.
- Do not operate if any wires are exposed in cables due to risk of electrical shock or burn.
- Use extreme caution when servicing any electrical component.
- Keep out of reach from children.
- Keep fingers away from all moving parts.
- Inspect machine before use.
- Check that nuts and bolts are suitably tightened.
- Use this machine only for its intended use as described in this manual.
- Do not modify the machine in any way.
- Turn off and unplug the machine before conducting cleaning and maintenance.

Safety Assessment

It is critical to conduct a safety assessment to ensure that it complies with all local laws and industry accepted safety regulations.

If you require guidance on the installation of the machine or conducting a safety assessment, please contact LFA Machines.

Important Safety Information

READ THIS BEFORE OPERATING MACHINE

Symbols



WARNING

This signals potential risk for personal injury.



WARNING

This signals potential risk for electrical shock.



CAUTION

This signals potential risk for damage to the machine or other parts.

Modes for Stopping

In the case of an emergency during operation, immediately push the Emergency Stop button and unplug the FACF 3500®:



Prop. 65 Statement for CA Residents

Based on LFA Machines' current level of knowledge of our machines, the FACF 3500® does not require a Proposition 65 warning label.

Warning for Explosive Material

This machine is not explosion proof. LFA Machines recommends that you test your materials' explosivity before running them through this machine. If your materials are indeed explosive, do not use them with this machine.

Table of Contents

Copyright Notice	2
Important Safety Information	3
Intended Use	3
Personal Protection	3
General Hazards	3
Safety Assessment	3
Symbols	4
Modes for Stopping	4
Prop. 65 Statement for CA Residents	4
Warning for Explosive Material	4
FACF 3500® Components	6
Preface	7
Training	8
On-Site/Off-Site Training	8
Training via Video Chat/Phone	8
LFA Machines Articles	8
LFA Machines Videos	8
Installation	9
Tools and Materials Needed	9
Positioning the FACF 3500®	12
Controls	13
Settings and Adjustment	18
Maintenance	41
General Maintenance Prescriptions	41
Lubrication	41
Dismantling for Repair and Replacement	44
Wear Parts and Causes of Damage	45
Troubleshooting	78
Common Issues	78
Common Issues Continued	79
Common Issues Continued	80
De-Jamming the FACF® Range	81
Cleaning	83
Storing the FACF 3500®	86
Appendix	87
Glossary	87
Description of FACF® Range Parts	88
Food Grade Point of Contact Parts	89
Technical Specifications	89
Toolbox Contents	90
FACF 3500® Bearings List	95
Maintenance Checklist	96
Diagrams	97
Resources	116

FACF 3500[®] Components

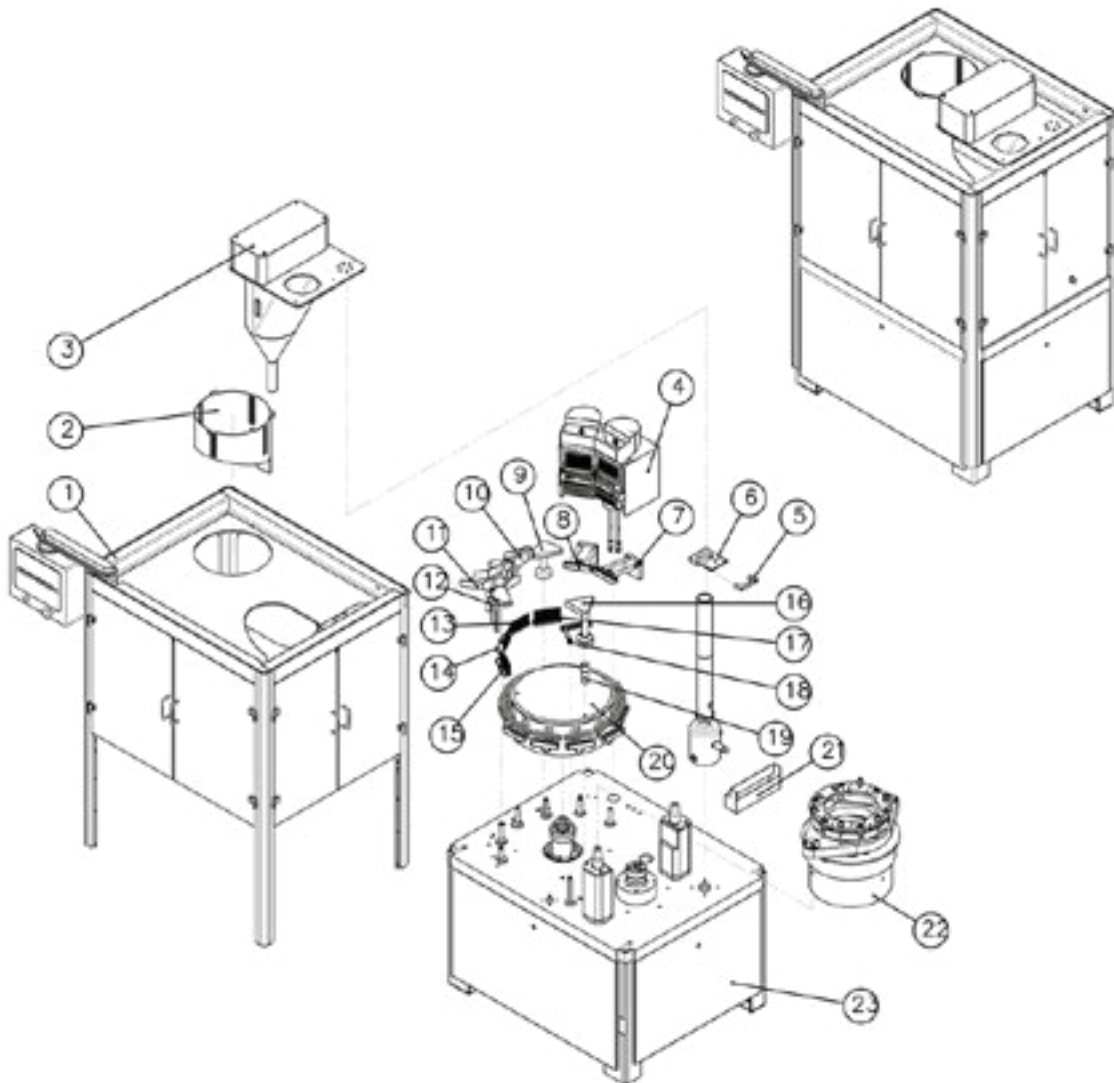

- | | |
|----------------------------------|--------------------------------------|
| 1. Enclosure Assembly | 13. Narrow Capsule Ejection Assembly |
| 2. Cylinder for Powder Hopper | 14. Wide Capsule Ejection Assembly |
| 3. Powder Hopper Assembly | 15. Press Rod Assembly |
| 4. Capsule Magazine Assembly | 16. Vacuum Rejection Assembly |
| 5. Detachable Press Plate | 17. Cleaning Assembly |
| 6. Detachable Plate | 18. Rejection Rod Assembly |
| 7. Capsule Separation Assembly 1 | 19. Joint |
| 8. Capsule Separation Assembly 2 | 20. Round Table Assembly |
| 9. Vacuum Cleaning Assembly | 21. Powder Container |
| 10. Capsule Ejection Assembly 1 | 22. Dosing Assembly |
| 11. Capsule Ejection Assembly 2 | 23. General Drive Assembly |
| 12. Capsule Press | |

Preface

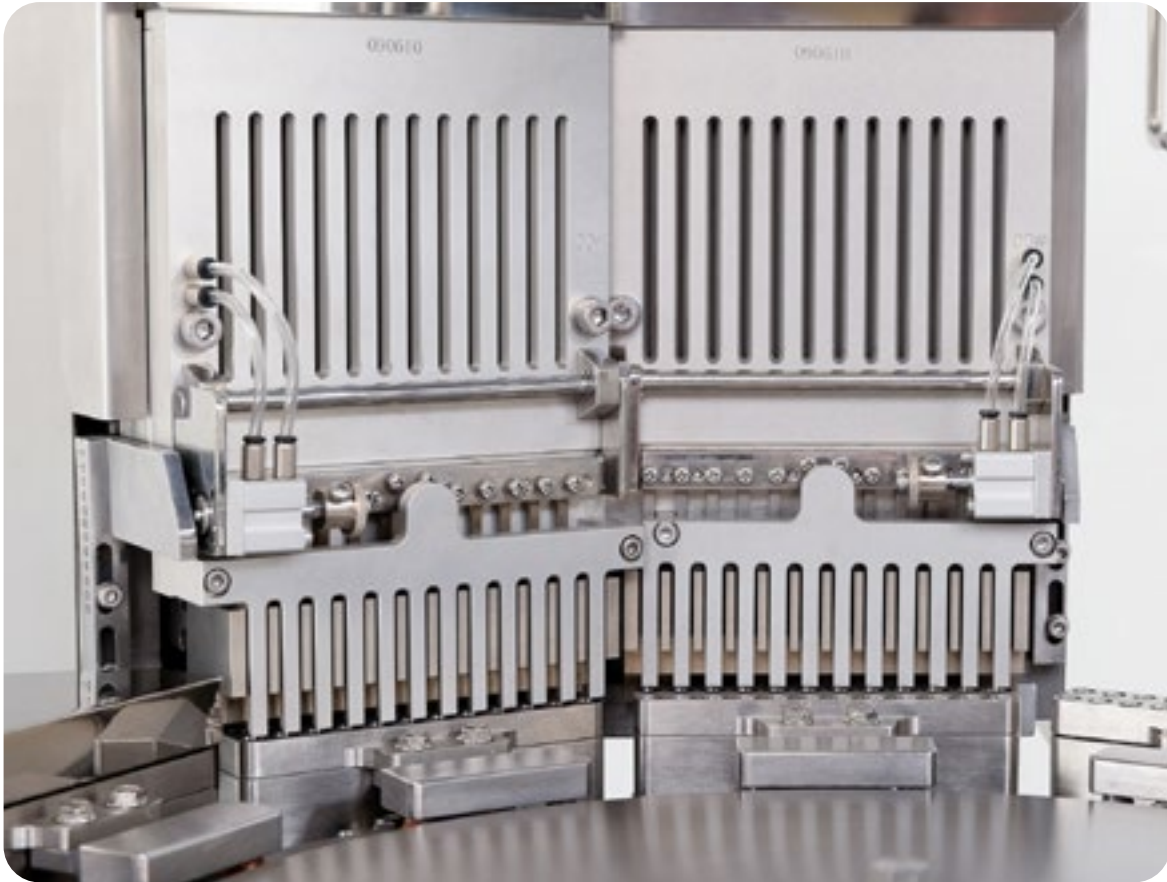

The FACF 3500® is a fully automatic capsule filler that accurately and efficiently produces capsules of varying sizes per minute. By using intermittent motion and stations for dosing and tamping, the FACF 3500® provides precise capsule orientation and dosing with a high filling rate. The FACF 3500® has been designed for exceptional output and efficiency while keeping batch profitability as high as possible with minimal downtime.

The purpose of this document is to support your understanding of the FACF 3500®'s components, features, functions, and design. With this manual, you will be able to successfully operate and maintain your FACF 3500® machine.

The user manual's content includes:

- Important safety information
- FACF 3500® installation instructions
- Description of the FACF 3500®'s operation
- FACF 3500® maintenance information
- Appendix with supplemental information



Training

FACF 3500® training is essential for the machine's successful operation and your personal safety. There are several methods to prepare you for working with the FACF 3500®.

On-Site/Off-Site Training

LFA Machines technicians can travel and train you at your own facility with your own machines. LFA Machines also offers free training at our UK, USA, and Taiwan facilities for all our customers and their teams. For more information, go to lfacapsulefillers.com/services

Training via Video Chat/Phone

Using an online video chat system, an LFA Machines technician can interact face-to-face with you and assist with your understanding of the machine. Or, if you prefer, we can provide training via phone for all customers who call the office. To set up a training, call or email your local office:

USA

Phone

+1 (682) 312-0034

Email

support.usa@lfamachines.com

UK

Phone

+44 01869 250234

Email

support.uk@lfamachines.com

Taiwan

Phone

+886 422031790

Email

support.asia@lfamachines.com

LFA Machines Articles

We write informative articles about capsules and capsule fillers, which includes instructions, procedures, and guides. To access the articles, go to lfacapsulefillers.com/articles

LFA Machines Videos

LFA Machines has created several videos involving the FACF 3500® and other capsule fillers. To access the videos, go to lfacapsulefillers.com/videos or youtube.com/channel/UCwtbcwja77ai7vX2o34FUkQ

Installation

Tools and Materials Needed

Before you install and operate the FACF 3500[®], it is best to have the following tools and materials on hand for general operation and maintenance:

- Forklift
- Pallet jack
- Crowbar
- Hammer
- Socket wrench set
- Metric wrench set
- Crosshead screwdriver
- Flathead screwdriver
- Set of metric Allen keys with ball ends
- Feeler gauge
- Long wire pipe cleaner
- Toothbrush
- Cleaner (e.g. Member's Mark Commercial Lemon Disinfectant)
- Sanitizer (e.g. Member's Mark Commercial Sanitizer)
- Lubricant (NSF-approved type for food grade products)
- Permanent marker
- Cleaning brush/paintbrush
- Plastic sheet or something similar to cover machine
- Safety goggles
- Hairnet and/or beard net (food grade products only)
- Sterile shoe covers (food grade products only)

The Appropriate Workstation for the Machine

The floor on which the machine is to be placed must support the FACF 3500[®]'s 1700 kg (about 3,747 lbs) weight. The table below shows the static floor loading limit for the FACF 3500[®]:

Machine	Static Floor Loading Limit
FACF 3500 [®]	26.8 kN/m ²

The machine's motor requires a three-phase power supply of 208 V/60 Hz. Ensure to position the machine near an appropriate electrical plug.

Environmental Conditions

It is important that the environment in which you operate and store the FACF[®] machine has the appropriate temperature and relative humidity levels. These two environmental factors can potentially cause the machine to rust and/or cause the capsules to have a lower quality. The table below shows the acceptable temperature and relative humidity levels:

Machine	Temperature		Humidity
	°C	°F	
FACF [®]	15-30	59-86	40-60% RH

The shipping crate will contain the following:

1. The FACF 3500®



2. The Tooling (already installed)

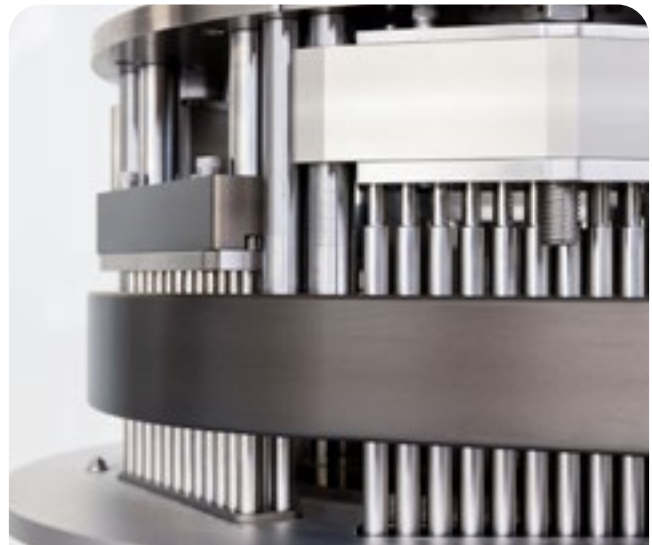

3. Anti-vibration feet
4. Vacuum, Vacuum Pump, and Filter
5. Toolbox (refer to contents list in Appendix for more information)

Unpacking the FADF 3500®

Tools Needed

- Crowbar
- Hammer
- Socket wrench set
- Forklift (lift 4000 lbs minimum)
- Anti-vibration feet

Instructions

1. Pry open each side of the shipping container with a crowbar and hammer and remove them.
2. Remove the Filter, Vacuum Pump, Toolkit, and Power Cable.
 - 2.1 Note: Be careful not to drop the heavy Vacuum Pump.
3. Remove the bolts on the shipping container's base with a socket wrench.
 - 3.1 Note: Keep the nuts, bolts, and the shipping container's base in case you need to move or relocate the machine.
4. Place the forklift underneath the machine and lift it.
 - 4.1 Note: Lift the machine high enough to insert the anti-vibration feet.
5. Attach the anti-vibration feet to each bottom corner of the machine (if needed).
6. Carefully lower the machine to the ground.

Positioning the FACF 3500®



WARNING: To prevent personal injury, wear steel toe boots and heavy duty grip gloves while transporting the FACF 3500®.

Because of its weight, LFA Machines does NOT recommend carrying the machine manually but rather with a forklift. At least two people should be involved (one operating the forklift and one stabilizing the machine) in removing the machine from the shipping container and placing it in the workspace.

Moving the FACF® with a Forklift

Tools Needed

- Forklift
- Heavy duty grip gloves
- Steel toe boots

Instructions

1. Raise the machine from the ground with a forklift.
2. Carefully guide the machine to the desired location.
 - 2.1 Note: The machine's motor requires a three-phase power supply of 220 V or 440 V. Ensure to position the machine near an appropriate electrical plug.
3. Carefully lower the forklift until the anti-vibration feet make contact with the floor.
4. Place the Filter on top of the Vacuum Pump.
 - 4.1 Note: Use plumber's tape around the threaded part of the Vacuum Pump to ensure a good seal to reduce pressure loss.
5. Plug in the Vacuum Compressor and main power cable.
6. Plug in the Vacuum Pump's hose and tighten it with a flathead screwdriver.
7. Insert the 8 mm/12 mm push fit airline.

Controls

Basic Components

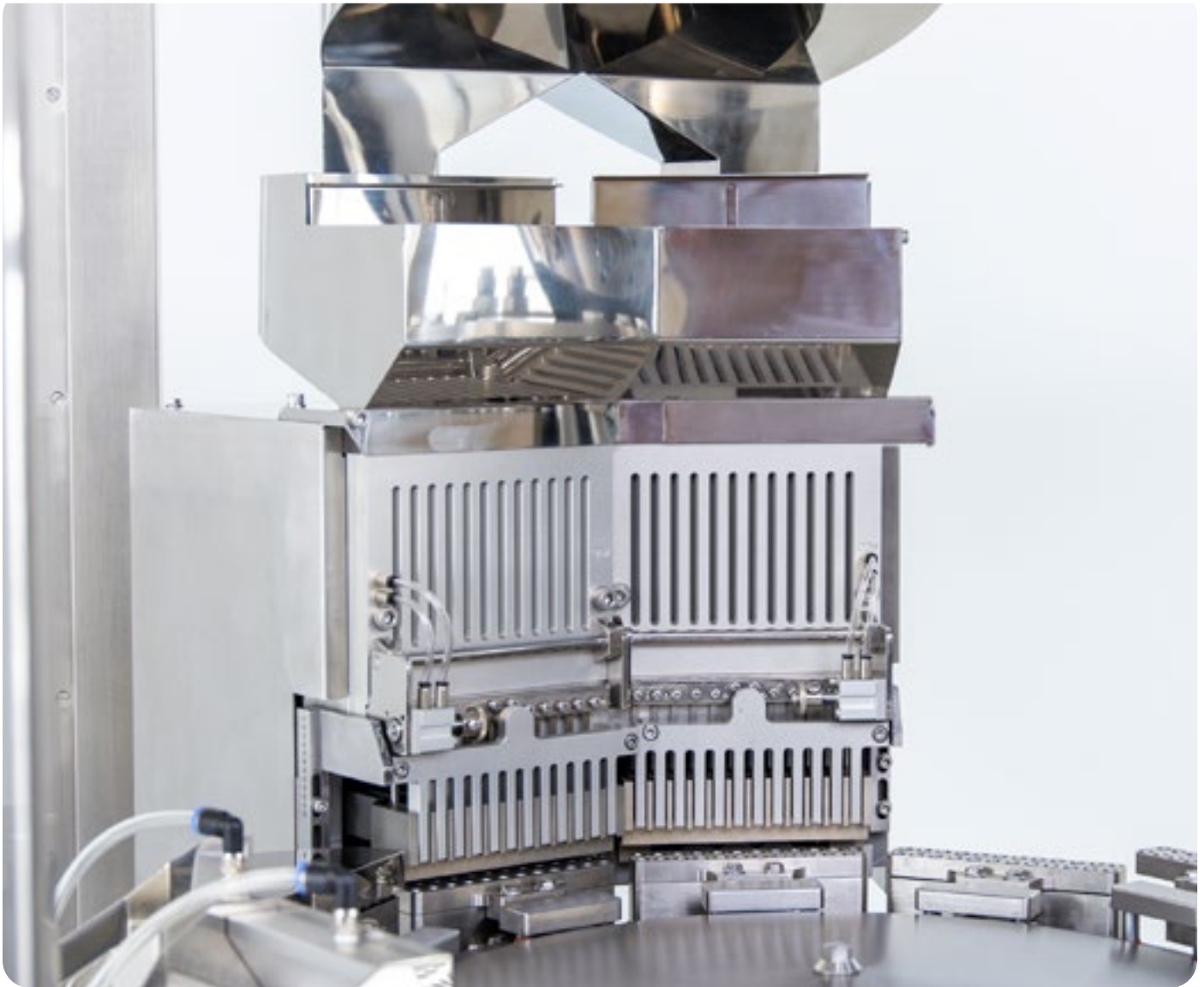

A description of the principal components follows:

- The **Capsule Hopper** hold the empty capsules.
- The **Capsule Sewing Stations** align the capsules in the correct position with a magazine and insert them into the capsule die segments.
- The **Vacuum System** separates the capsule caps and bodies.
- The **Powder Hopper** contains the mix that will be encapsulated.
- The **Auger** distributes the mix into the Tooling station and into the capsule bodies.
- The **Tamping Station** compresses the powder into a slug, which then gets pushed into the capsule body.

Control Console



1. Run machine
2. Emergency Stop

Main Digital Control Console

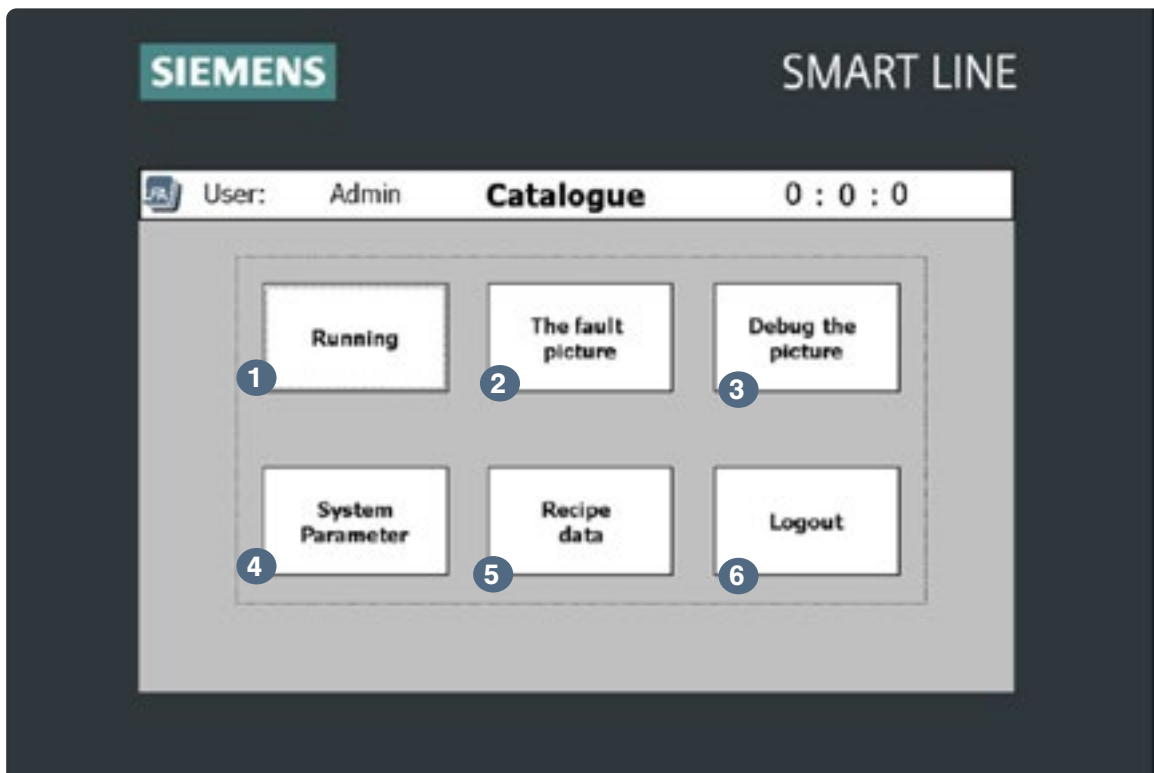

1. Main production display that turns on and off operation, jog mode, vacuum pump, and other settings.
2. Shows machine alarms that prevent the machine from running such as Emergency Stop being on or a perspex door being open.
3. Debug the picture
4. Set machine parameters.
5. Input/see formulation recipe information.
6. Return to login screen.

FACF 3500® Process

The basic mechanism of the FACF 3500® involves orienting, separating, filling, closing, and ejecting capsules.

Orienting and Inserting Capsules into the Capsule Die Segments

When the machine begins operation, the capsules in the Hoppers are fed into the magazines vertically. With each movement of the machine, the gates of the Capsule Magazines release one capsule, and the horizontal forks orientate it. Then, the vertical forks push the capsules into the Capsule Die Segments with all caps in the upward position.



Filling the Capsule Bodies with Powder

After the vacuum system separates the capsule bodies and capsule caps, the lower Capsule Die Segment with the capsule bodies is extended. The filling rod then pushes the pressed powder slug in the capsule bodies.



Capsule Sealing and Ejection

Once defective capsules have been rejected, the capsules are snapped shut. After that, the finished capsules are ejected and then cleaned by the vacuum cleaner and compressed air.



How to Fill Capsules with the FACH 3500®

Tools and Materials Needed

- Empty capsules
- Raw material formulation
- Fully assembled FACH 3500®
- Receptacle for filled capsules
- Safety goggles
- Disposable latex/rubber gloves (for food grade products and to protect hands from grease)
- Hairnet and/or beard net (food grade products only)
- Sterile shoe covers (food grade products only)

CAUTION – PRIOR TO OPERATING MACHINE: Check to see that all four panel doors of the machine are completely shut (there are sensors on them that prevent the machine from running if any panel door is open).



Manually rotate for 1-3 cycles. Then, press the green button, push the vacuum pump button on the touch screen and check the direction of the rotation. If it is rotating in the wrong direction, the power supply's phase sequence needs to be changed.

Ensure that there is a sufficient amount of powder in the Powder Hopper.

Ensure to start the vacuum pump first before starting the main motor.

Instructions

Note: Wear latex/rubber gloves (and appropriate food grade attire if applicable) during this process.

1. Place the receptacle for filled capsules near the ejection chutes.
2. Pour the empty capsules into the Capsule Hopper.
3. Turn the Isolator Switch to power on the machine.
4. Press the Enter button to enter the main screen, enter the login information, and press Enter again.

4.1 Note: There are two logins for operators of this machine. The login information is:

Username: 1 Password: 111

Username: 2 Password: 222

5. Press the Running button.

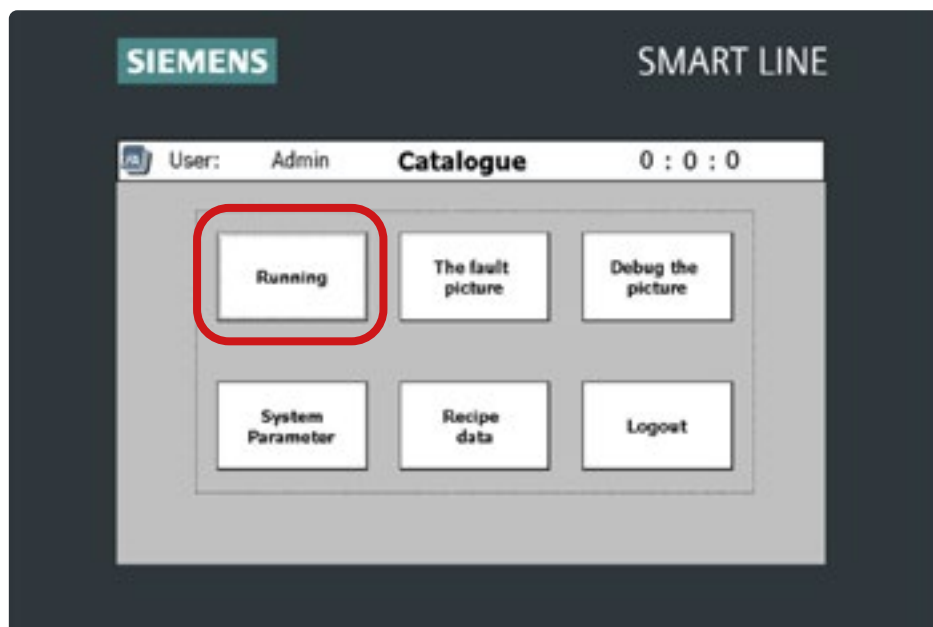

6. Press the Pump Off button so that it changes to Pump On.
7. Press the Capsule loader off button so that it changes to Capsule loader on.
8. Press the Vacuum Feed off button so that it changes to Vacuum Feed on.
9. Press the Capsule Valves off button so that it changes to Capsule Valves on.
10. Press the green Run button.

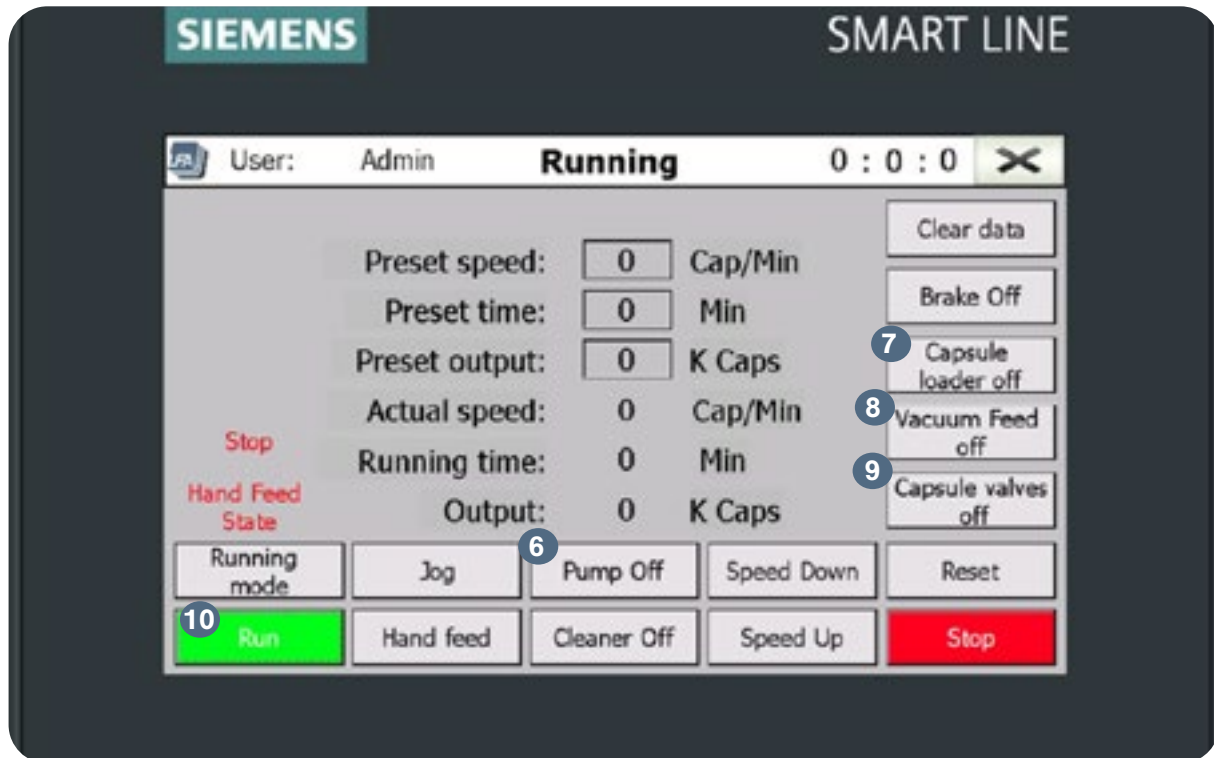

Settings and Adjustment

The FACF 3500®'s settings can be adjusted. Tuning the machine can help with changing the capsule dose and machine operation.

Main Speed

The FACF 3500® main speed for capsule output can be changed via the Running display screen from the Startup display screen.

Tools and Materials Needed

- Disposable latex/rubber gloves (for food grade products and to protect hands from grease)
- Hairnet and/or beard net (food grade products only)
- Sterile shoe covers (food grade products only)

Instructions

Note: Wear latex/rubber gloves (and appropriate food grade attire if applicable) during this process.

1. Click the Running button from the Startup screen.
2. Press the Speed Down and Speed Up buttons to adjust the operation speed.

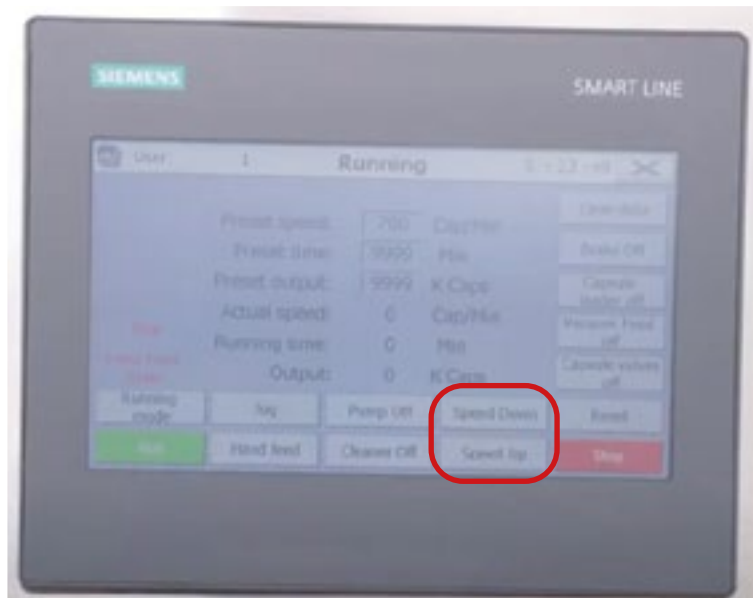

3. Ensure that the ejected capsules have a consistent weight after the adjustment.
 - 3.1 Note: Powders with poor flow will have issues with increased speed.

Capsule Weight Adjustment

Tuning the FACF 3500® involves adjusting the five tamping stations located below the Powder Hopper. The weight of the capsule can be increased or decreased by making these adjustments. To watch a video of tuning a similar FACF®, go to lfacapsulefillers.com/videos/tuning-your-facf-capsule-filler

Tools and Materials Needed

- Metric wrench set
- Disposable latex/rubber gloves (for food grade products and to protect hands from grease)
- Hairnet and/or beard net (food grade products only)
- Sterile shoe covers (food grade products only)



WARNING: To prevent any potential personal injury, ALWAYS unplug the FACF 3500® from the electrical outlet when making adjustments.

Instructions

Note: Wear latex/rubber gloves (and appropriate food grade attire if applicable) during this process.

1. Manually turn the machine using the handle insert on the right side of the machine until the tamping pins are at their lowest position.
2. Open the machine's Perspex casing doors.
3. Loosen the two nuts on all of the capsule weight adjusters with a wrench.

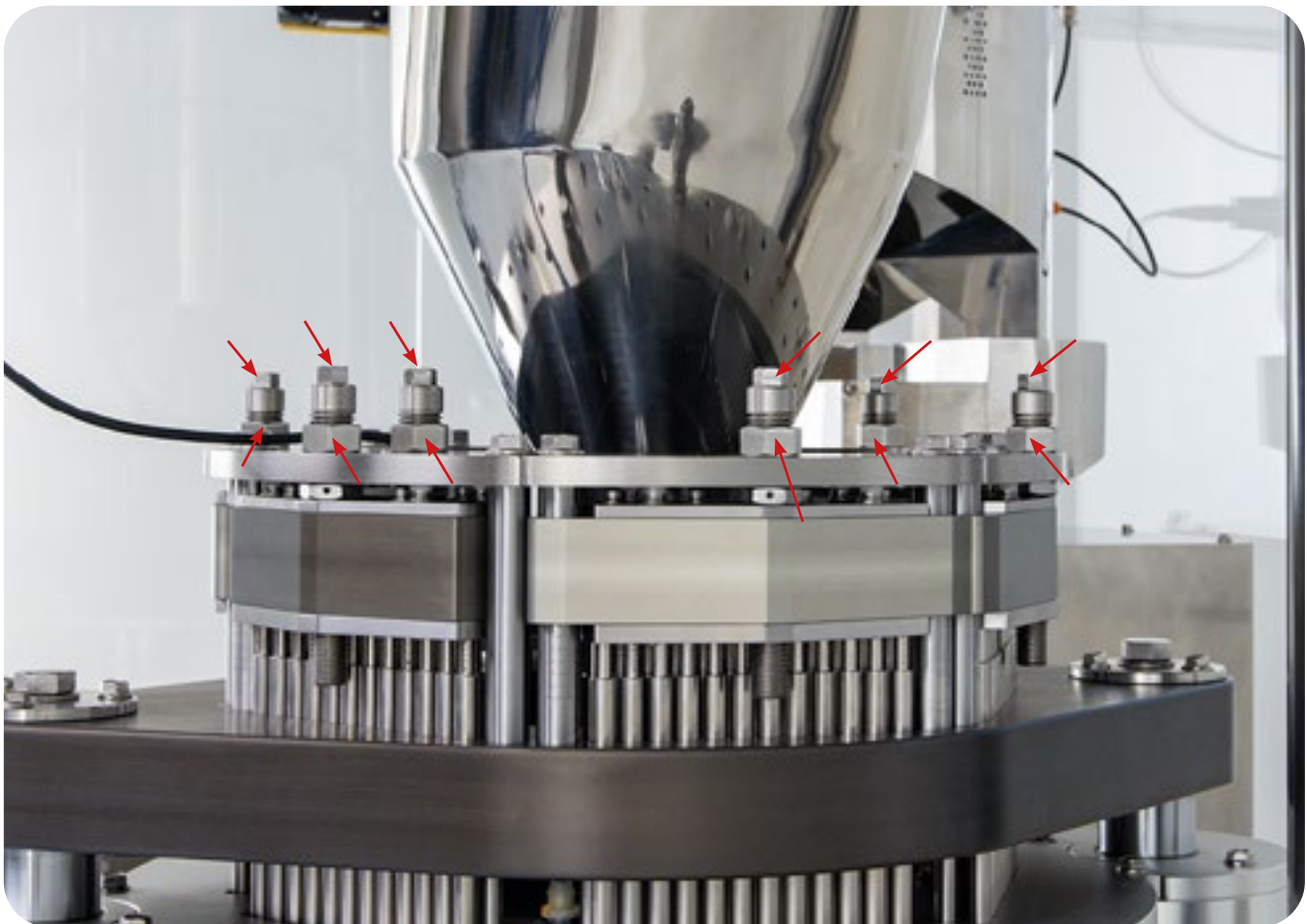

NOTE: Read this before making adjustments. The capsule weight adjustment knobs **MUST** be turned sequentially beginning with the lowest and continuing with the highest.

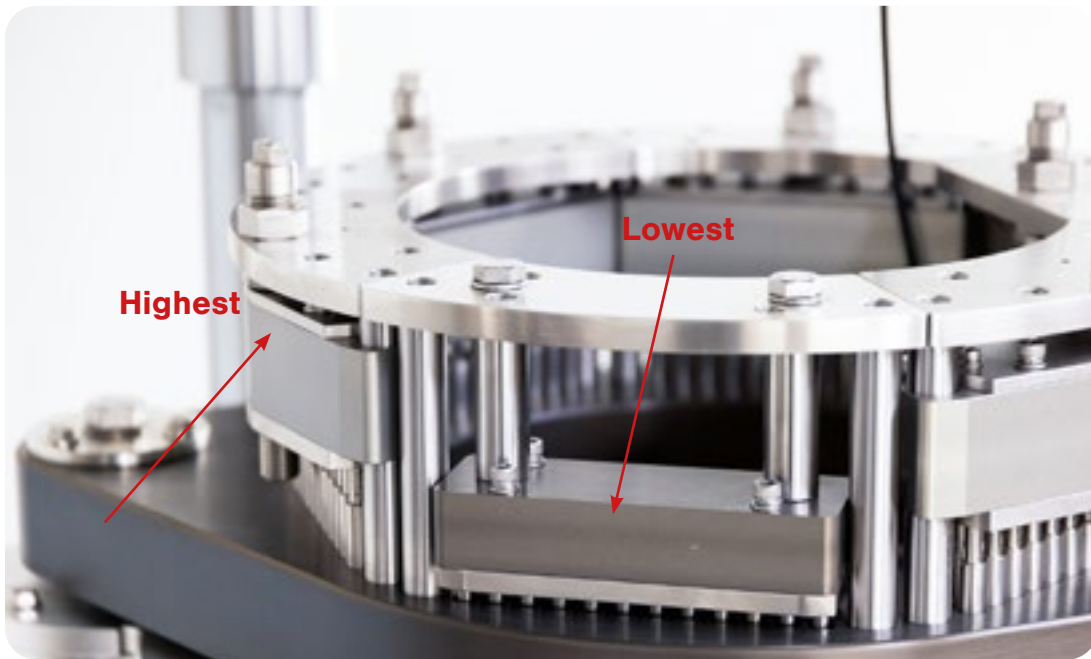

4. Turn each adjustment knob to meet the following measurements on the gauge:

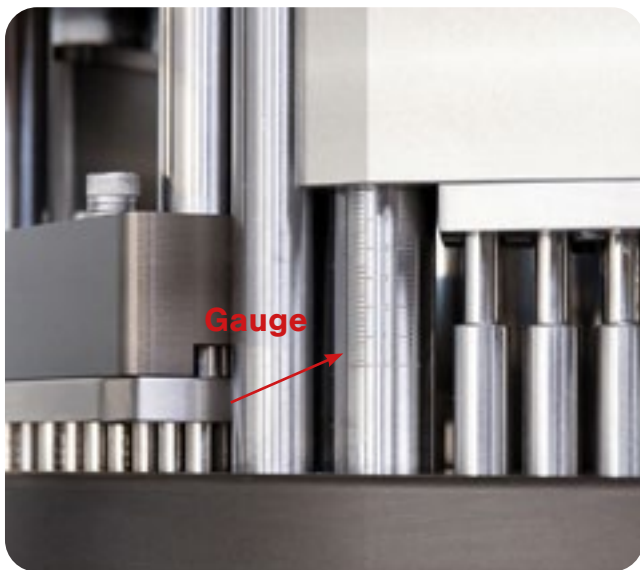

No. of working station (lowest to highest)	1 (lowest)	2	3	4	5 (highest)
Insertion depth (mm)	9	5	3	2	1 or 0

Note: Raise the knobs to decrease the weight and lower them to increase the weight.

5. Tighten each station's adjustment bolt with a wrench.
6. Manually operate the machine to determine if weight adjustment is correct.



WARNING: To prevent any potential personal injury, remove the Handle from the Motor before plugging in machine and automatic operation.

Capsule Hopper Adjustment

This adjustment affects the flow of the capsules from the Capsule Hopper to the Capsule Magazine. If the flow rate is too high, capsules can spill over. If it is too low, capsules will not enter the Capsule Die Segments.

Tools and Materials Needed

- Disposable latex/rubber gloves (for food grade products and to protect hands from grease)
- Hairnet and/or beard net (food grade products only)
- Sterile shoe covers (food grade products only)



WARNING: To prevent any potential personal injury, ALWAYS unplug the FACF 3500® from the electrical outlet when making adjustments.

Instructions

Note: Wear latex/rubber gloves (and appropriate food grade attire if applicable) during this process.

1. Rotate the lock to loosen the Capsule Hopper's gate.



2. Slide the gate up and/or down to adjust the capsule flow.
 - 2.1 Note: Sliding the gate up increases the flow of the capsules. Sliding the gate down decreases the flow of the capsules.

Capsule Feeding Gate Adjustment

The correct timing of the retaining gate ensures that one capsule comes out of the magazine fork at a time.

Tools and Materials Needed

- Set of Allen keys with ball ends
- Disposable latex/rubber gloves (for food grade products and to protect hands from grease)
- Hairnet and/or beard net (food grade products only)
- Sterile shoe covers (food grade products only)



WARNING: To prevent any potential personal injury, ALWAYS unplug the FACF 3500® from the electrical outlet when making adjustments.

Instructions

Note: Wear latex/rubber gloves (and appropriate food grade attire if applicable) during this process.

1. Remove the fastening screws with an Allen key.

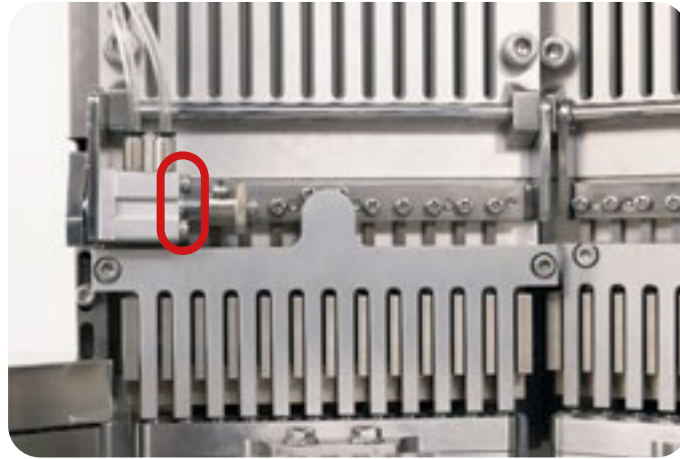

2. Adjust the limit block until one capsule is correctly discharged from the magazine at a time.
 - 2.1 Note: Raise the limit block up and away from the Capsule Magazine if not enough capsules are coming out. Adjust it down and towards the Capsule Magazine if too many capsules are coming out. If only one track of the Capsule Magazine is not putting out capsules, one of the springs may be bent.

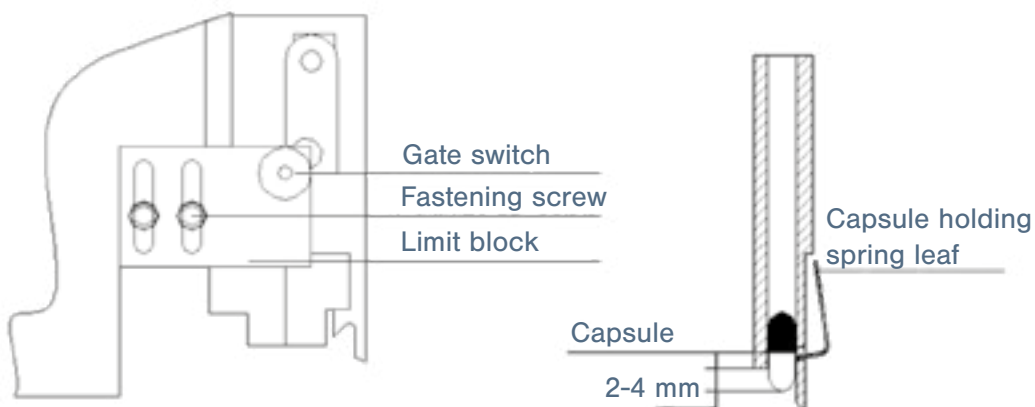

Dosing Disk and Seal Ring Gap Adjustment

The gap between the Dosing Disk and the seal ring should be between 0.05 mm to 0.1 mm. If the powder's granules are large, the gap should be increased as a smaller gap could cause resistance between the Dosing Disk and seal ring. Powder leakage can also indicate if the gap is too large.

Tools and Materials Needed

- Set of Allen keys with ball ends
- Set of metric wrenches and sockets
- Feeler gauge
- Disposable latex/rubber gloves (for food grade products and to protect hands from grease)
- Hairnet and/or beard net (food grade products only)
- Sterile shoe covers (food grade products only)



WARNING: To prevent any potential personal injury, ALWAYS unplug the FACF 3500® from the electrical outlet when making adjustments.

Instructions

Note: Wear latex/rubber gloves (and appropriate food grade attire if applicable) during this process.

1. Remove the Powder Hopper from the machine with a wrench along with any excess powder.

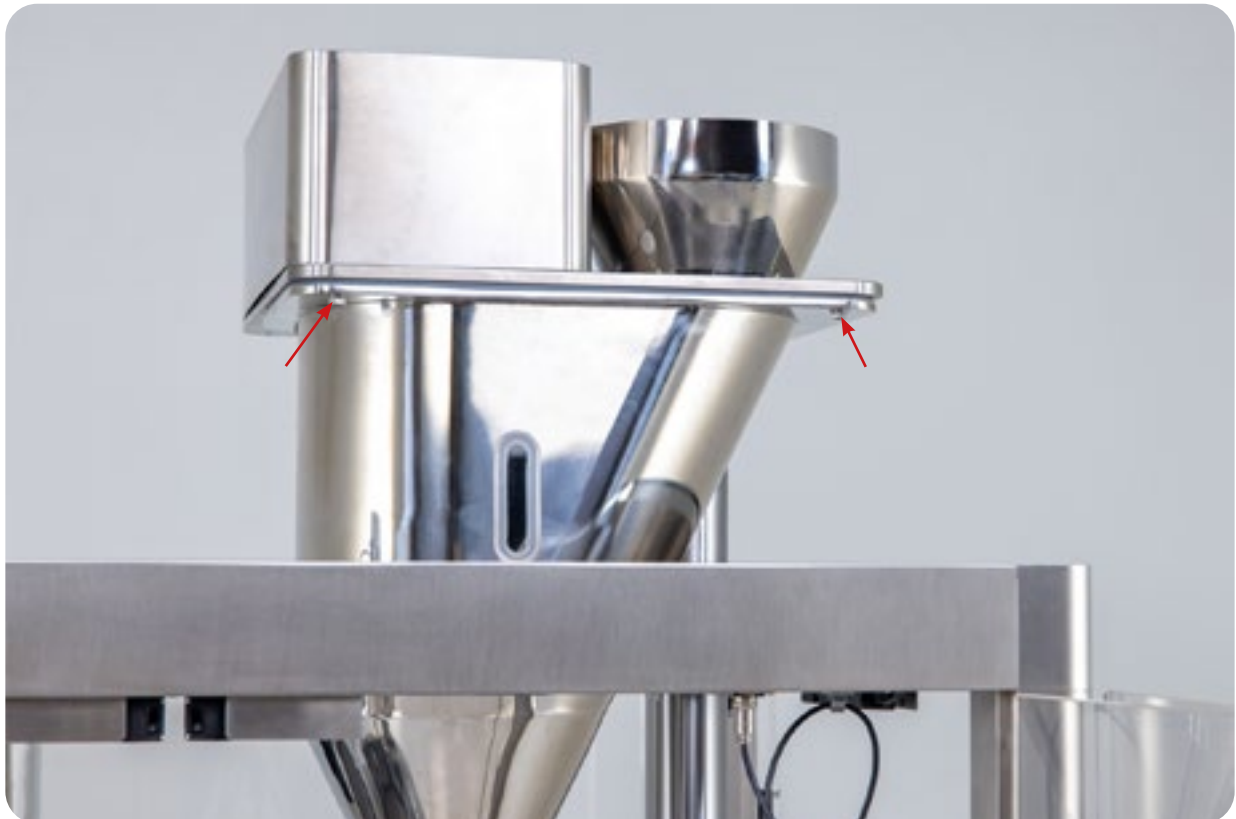

2. Remove the Powder Hopper Auger by shifting it loose.

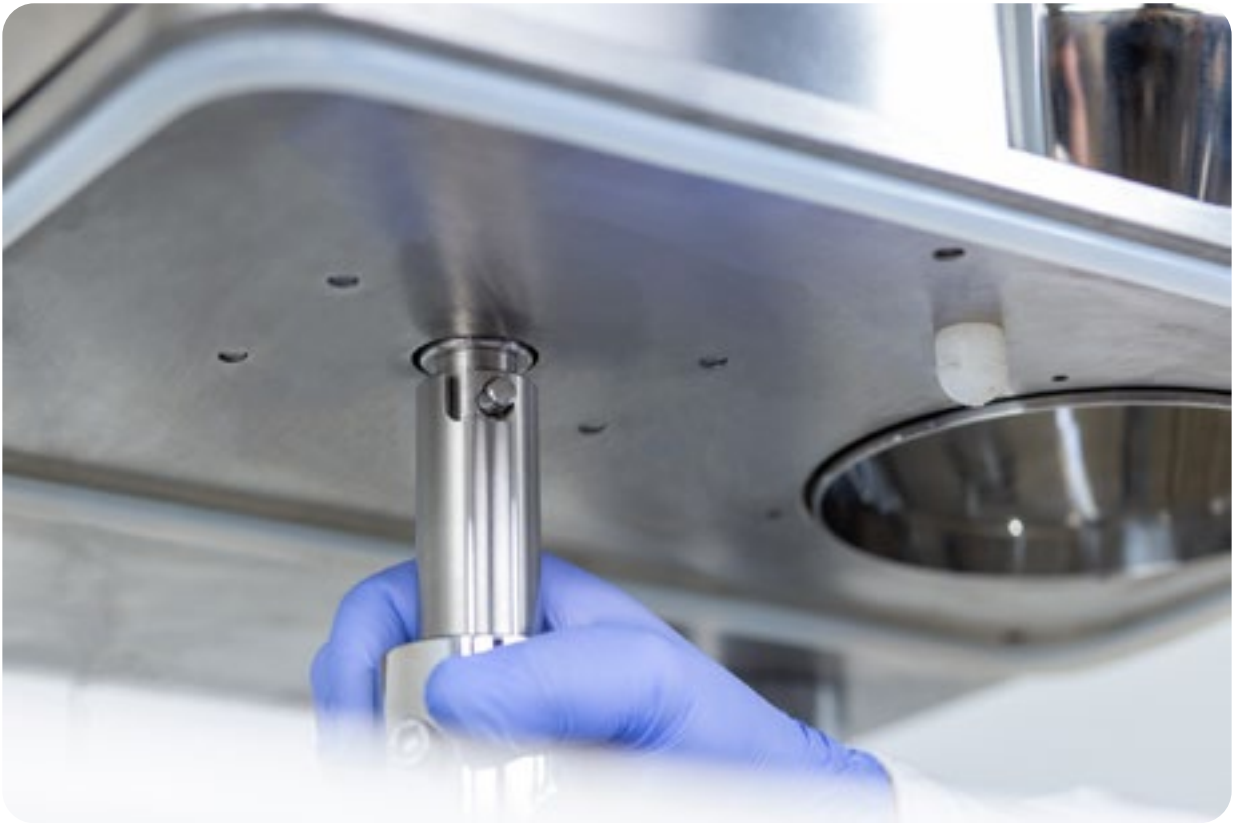

3. Manually rotate the machine by hand to move the tamping pin holder to the highest position.

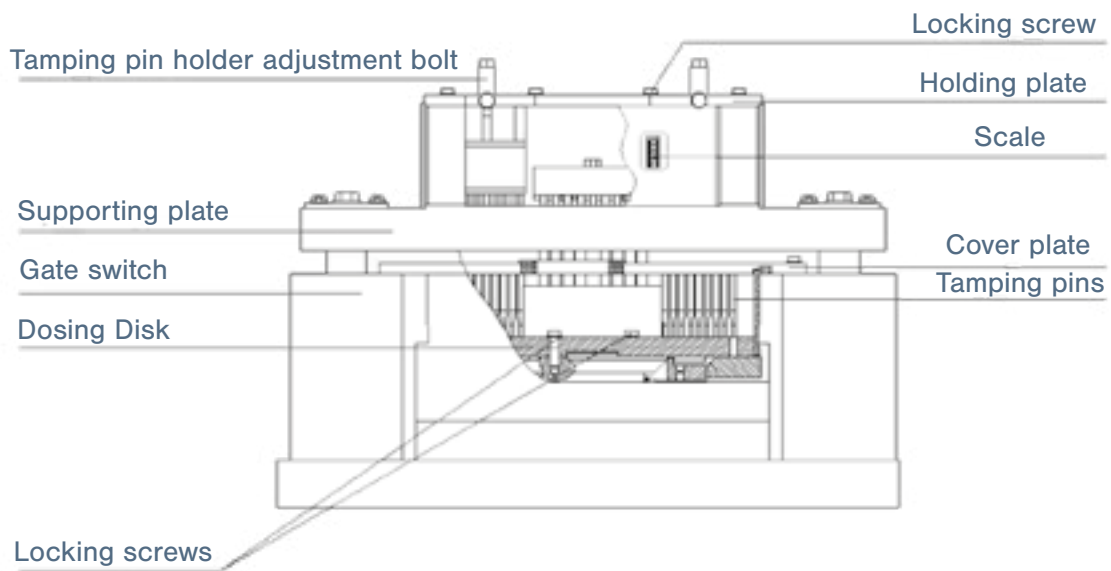

4. Loosen the screws on each of the tamping pin holders to remove the holders.

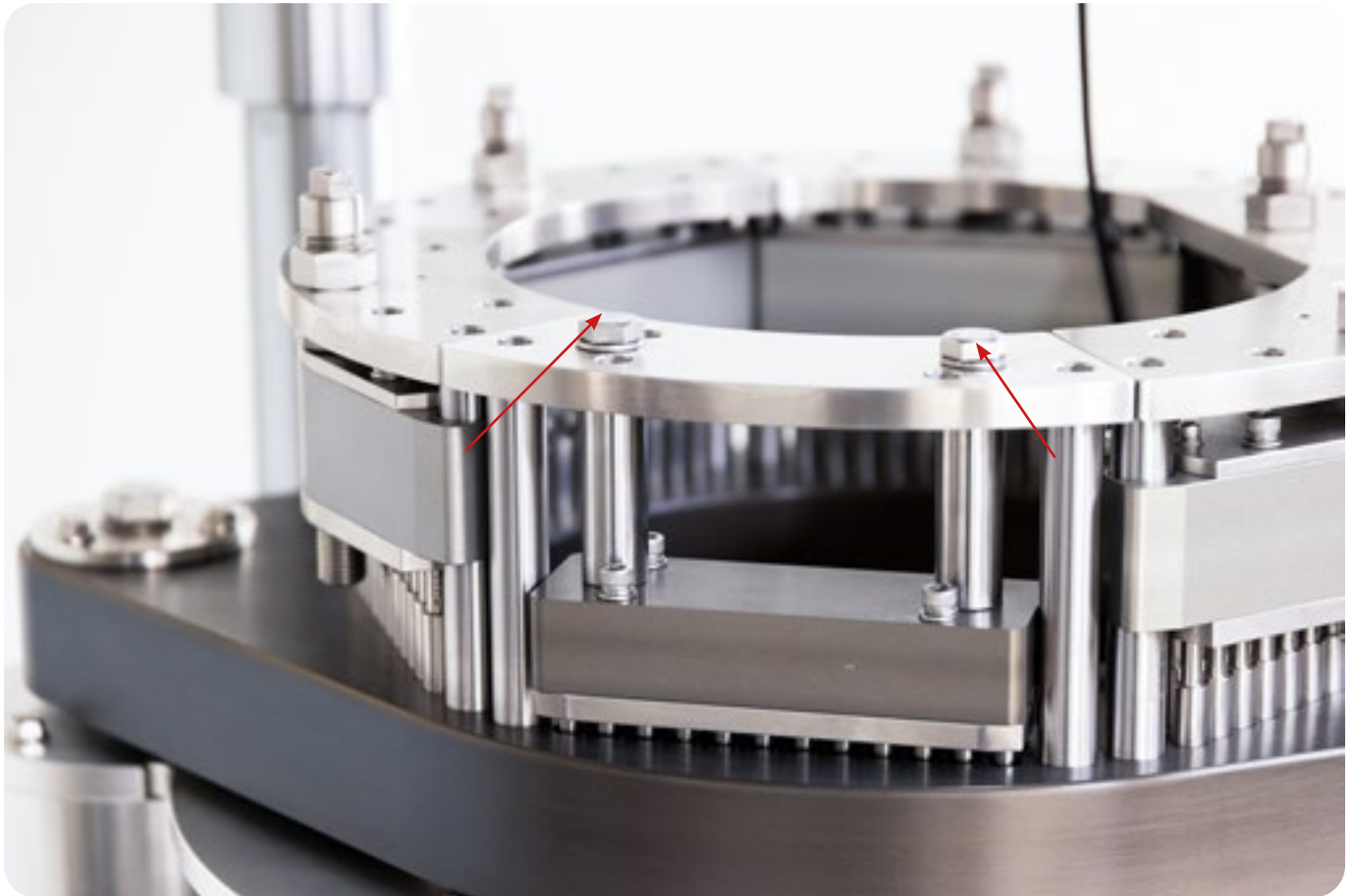

5. Loosen the two big screws on both sides of the supporting plate to take it off.



6. Remove the screws of the powder trough cover and take it off.



7. Loosen the six screws that secure the Dosing Disk and clean any excess powder between the Dosing Disk and seal ring.

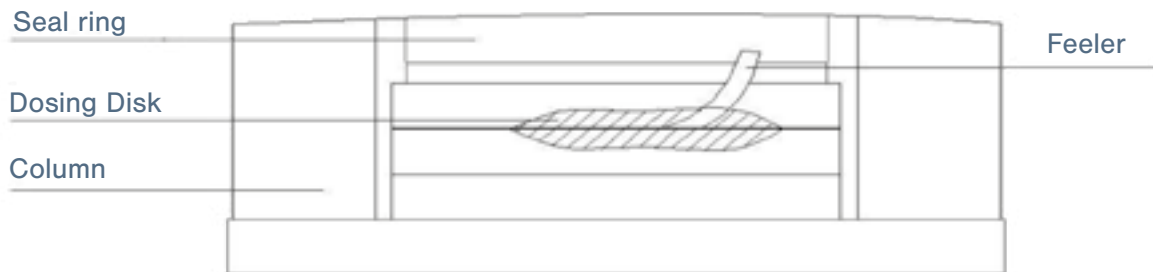
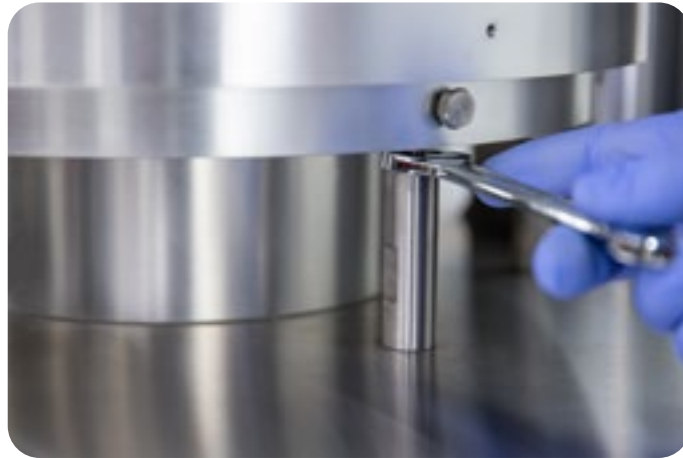

8. Rotate the bolt to adjust the gap between the Dosing Disk and sealing ring.

8.1 Note: Rotate the bolt counterclockwise to lower the seal ring. Rotate the bolt clockwise to raise the seal ring.

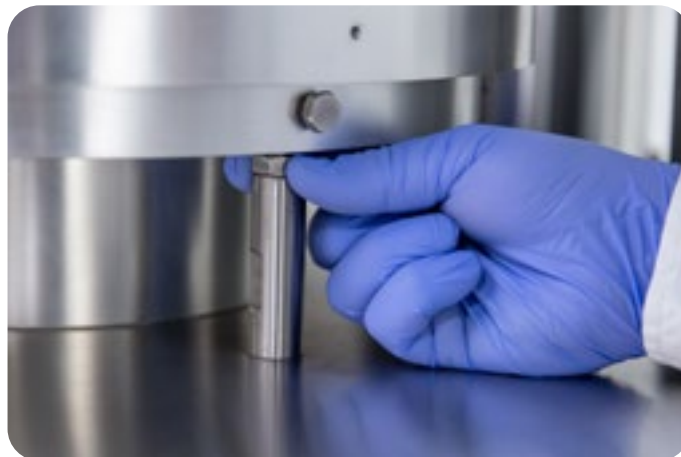

9. Measure the gap with a feeler gauge to ensure that it is between 0.05 mm and 0.1 mm.



10. Tighten the screws and reassemble the dosing section of the machine.

Powder Scraper Adjustment

Anytime the Dosing Disk is replaced, the gap between the powder scraper and the Dosing Disk must be adjusted. The optimal measurement of the gap is 0.05 mm to 0.1 mm.

Tools and Materials Needed

- Set of Allen keys with ball ends
- Set of metric wrenches
- Feeler gauge
- Disposable latex/rubber gloves (for food grade products and to protect hands from grease)
- Hairnet and/or beard net (food grade products only)
- Sterile shoe covers (food grade products only)



WARNING: To prevent any potential personal injury, ALWAYS unplug the FACF 3500® from the electrical outlet when making adjustments.

Instructions

Note: Wear latex/rubber gloves (and appropriate food grade attire if applicable) during this process.

1. Remove the Powder Hopper from the machine and remove any excess powder.
2. Loosen the fixed screws that are above and under the cover plate.

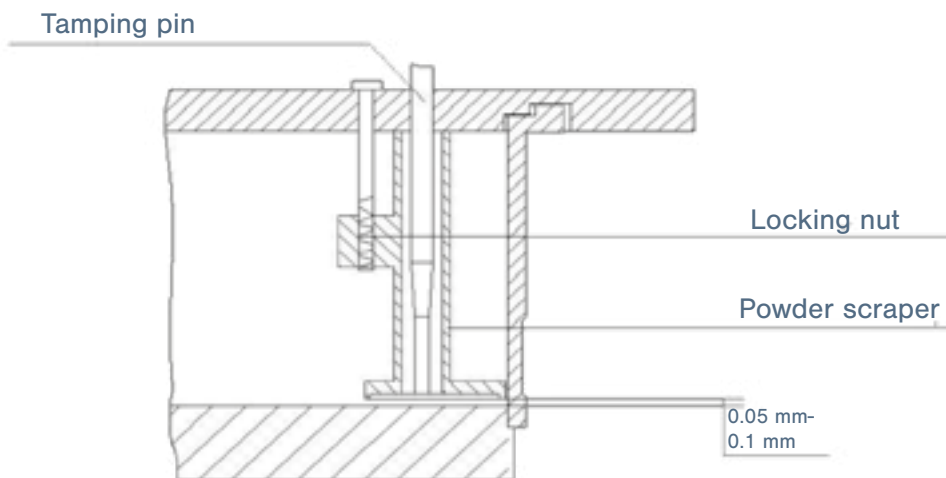

3. Rotate the adjusting screw to raise or lower the powder scraper.
4. Measure the gap with a feeler gauge to ensure that it is between 0.05 mm and 0.1 mm.
5. Tighten the fixed screws after determining the correct adjustment.

Powder Sensor Adjustment

If the machine's sensor is unable to detect powder, its sensitivity must be adjusted.

Tools and Materials Needed

- Set of Allen keys with ball ends
- Set of metric wrenches
- Metric ruler
- Disposable latex/rubber gloves (for food grade products and to protect hands from grease)
- Hairnet and/or beard net (food grade products only)
- Sterile shoe covers (food grade products only)



WARNING: To prevent any potential personal injury, ALWAYS unplug the FACF® from the electrical outlet when making adjustments.

Instructions

Note: Wear latex/rubber gloves (and appropriate food grade attire if applicable) during this process.

1. Loosen the powder lever sensor's screw and remove it from the clamp.

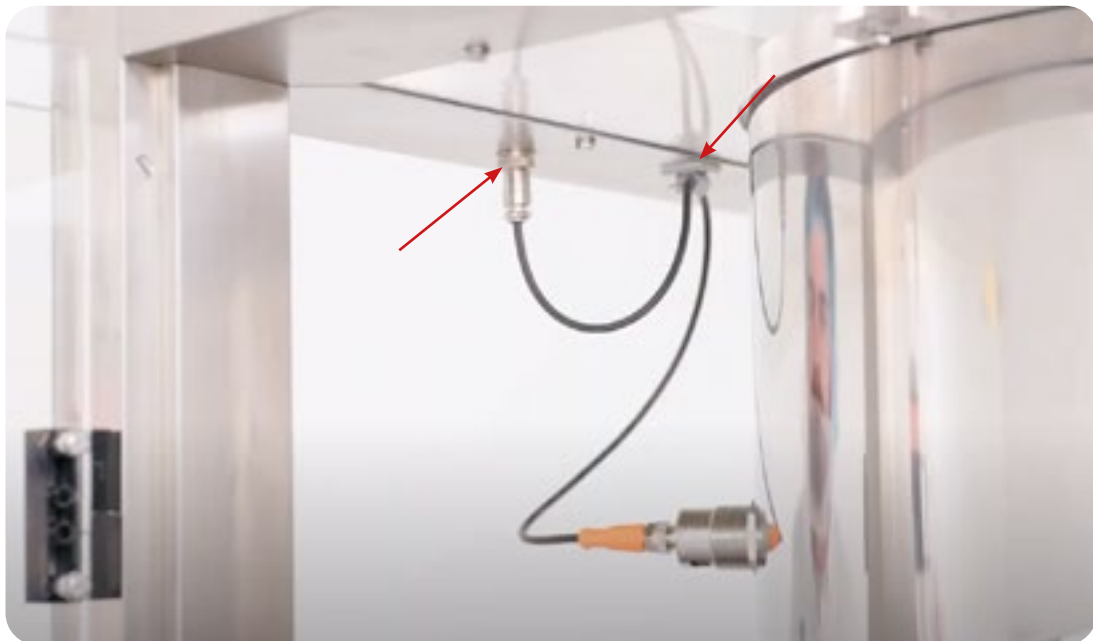

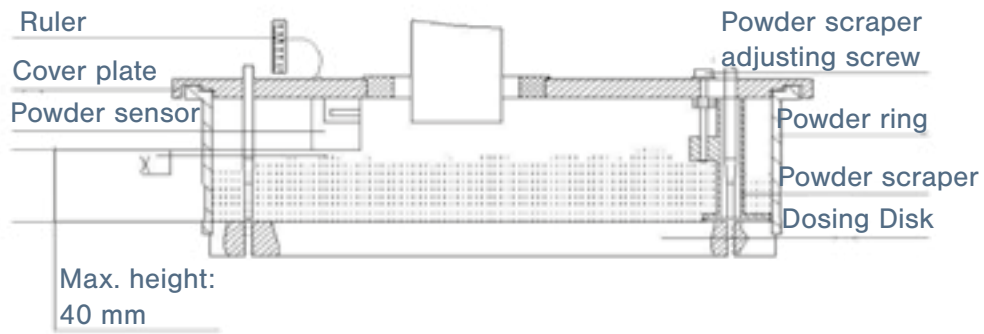

2. Adjust the sensor's height.

2.1 Note: Rotate the screw on top of the sensor to adjust the sensitivity. Increase the sensitivity if the sensor is unable to detect powder. However, if the Tamping Bowl is not filling with powder and the capsule weight is inconsistent, decrease the sensitivity. The distance between the sensor's terminal surface and the powder should be about 2 mm-8 mm.



Capsule Closing Adjustment

If capsules are not sealing, adjust the upper closing plate and the lower pushing rod in the 10th station.

Tools and Materials Needed

- Set of Allen keys with ball ends
- Set of metric wrenches
- Metric ruler
- Disposable latex/rubber gloves (for food grade products and to protect hands from grease)
- Hairnet and/or beard net (food grade products only)
- Sterile shoe covers (food grade products only)



WARNING: To prevent any potential personal injury, ALWAYS unplug the FACF 3500® from the electrical outlet when making adjustments.

Instructions

Note: Wear latex/rubber gloves (and appropriate food grade attire if applicable) during this process.

1. Loosen the 10th station's upper plate's screws to adjust the height.

1.1 Note: Ensure that the distance between the plate and the top of the capsule is 0.2 mm-0.3 mm.



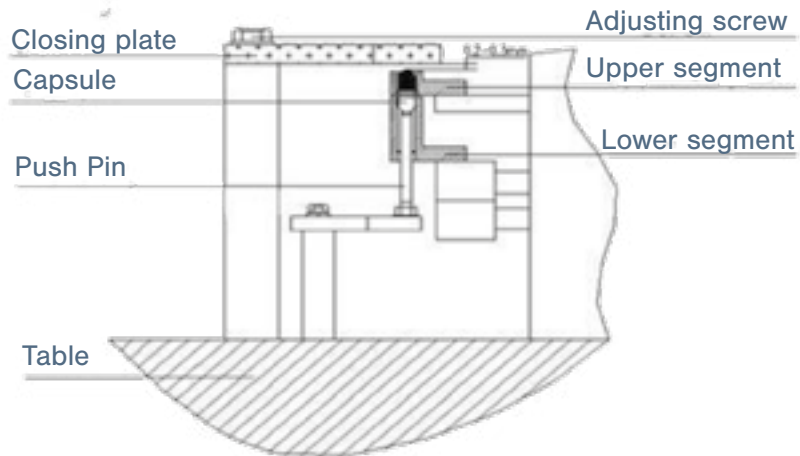

2. Insert an empty capsule into the Capsule Die Segment and manually rotate the machine by hand to move the pushing rod to the highest position.
3. Loosen the screws at both ends of the push pin and turn it to push up the capsule.
4. Tighten the screws whenever the capsule touches the closing plate and the push pin is at its highest point.
 - 4.1 Note: If the capsule reaches the plate before the push pin is at its highest point, lower the push pin.

Note: The Capsule Sealing Alignment Pins that are included in the FACF[®] toolbox can also help with adjusting the capsule closing section. Drop the two pins in the outer bores of the upper and lower capsule sealing segments. Adjust the push pins until the Capsule Sealing Alignment Pins easily fall into the segment bores.

Filled Capsule Ejection Adjustment

The adjustment of the ejection mechanism in the machine includes the guide plate and the pushing rod.

Tools and Materials Needed

- Set of Allen keys with ball ends
- Set of metric wrenches
- Disposable latex/rubber gloves (for food grade products and to protect hands from grease)
- Hairnet and/or beard net (food grade products only)
- Sterile shoe covers (food grade products only)



WARNING: To prevent any potential personal injury, ALWAYS unplug the FACF® from the electrical outlet when making adjustments.

Instructions

Note: Wear latex/rubber gloves (and appropriate food grade attire if applicable) during this process.

1. Loosen the guide plate's screws and move them to adjust the angle and position of capsule ejection.

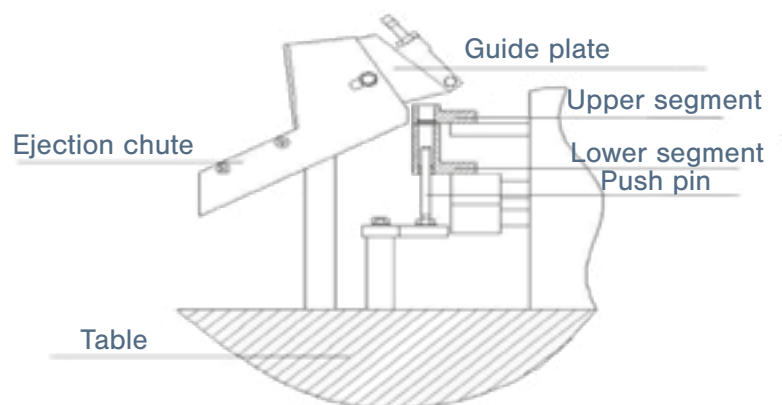

2. Loosen the screws at both ends of the push pin and turn it to adjust the ejection.

Timing Calibration

Calibrating the machine means checking the positions of the Die Segment Turret, Dosing Disk, Tamping Pins, and Sealing Pins, Ejection Pins, and Rejection Pins, which may require an adjustment of the position indicator.

Tools and Materials Needed

- Set of Allen keys with ball ends
- Set of metric wrenches
- Disposable latex/rubber gloves (for food grade products and to protect hands from grease)
- Hairnet and/or beard net (food grade products only)
- Sterile shoe covers (food grade products only)



IMPORTANT: The timing calibration **MUST** be adjusted in the following order:

1. Die Segment Turret
2. Dosing Disk
3. Tamping Pins
4. Sealing Pins, Ejection Pins, and Rejection Pins

Instructions

Note: Wear latex/rubber gloves (and appropriate food grade attire if applicable) during this process.

Part One: Die Segment Turret Timing and Set Up for Other Calibrations

1. Turn on the machine and go to the Running display screen.
2. Press the Brake Off button.

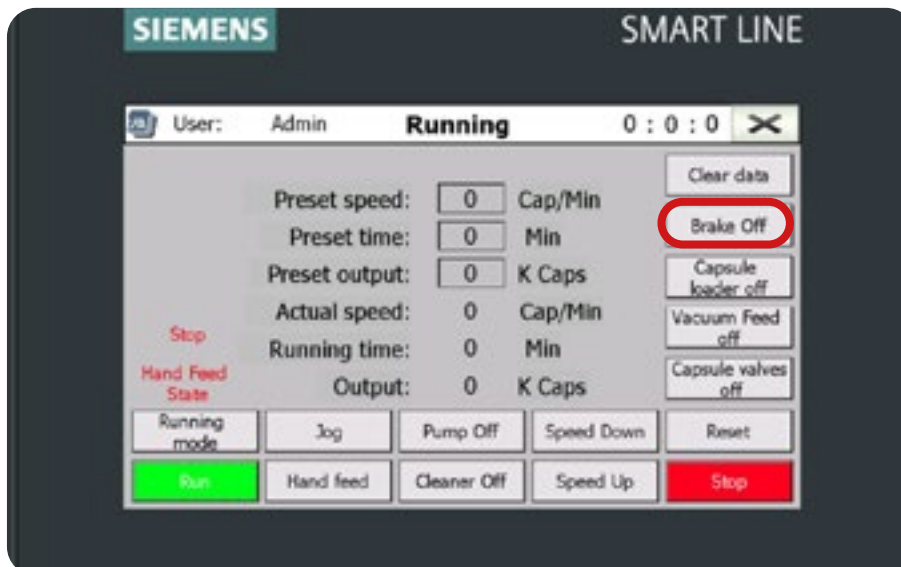

3. Rotate the machine by hand until the Die Segment Turret just begins to move.



4. Check the position indicator to ensure that the Die Segment Turret is at 360/360 degrees.
 - 4.1 Note: If it is not at this position, remove the bolt in the middle of the position indicator with an Allen key. Adjust the position indicator until it is at the correct degree and tighten its screw with an Allen key.



Part Two: Dosing Disk Timing

5. Manually rotate the machine until the position indicator is at 300 degrees.
6. Check to see that the Dosing Disk begins to move.



- If the Dosing Disk moves, skip to step #10. If it does not move, proceed to step #7.
7. Loosen the lock screw and Disconnect the chain from the chain joint.



8. Rotate the Tamping Section gearbox until it begins to move.
 - 8.1 Note: Do NOT turn the gearbox that is connected to the Die Segment Turret.
9. Reconnect the chain to the main drive motor.
 - 9.1 Note: Ensure NOT to move either gearbox. Causing any more movement during this step can disrupt the calibration, which would require the entire process to start over from the beginning.

Part Three: Adjust Tamping Pins Timing

10. Manually rotate the machine until the position indicator is at 20 degrees.
11. Check to see that the Tamping Pins begin to move upwards. If it does not, move the Tamping Pin Cam until it is in the correct position.

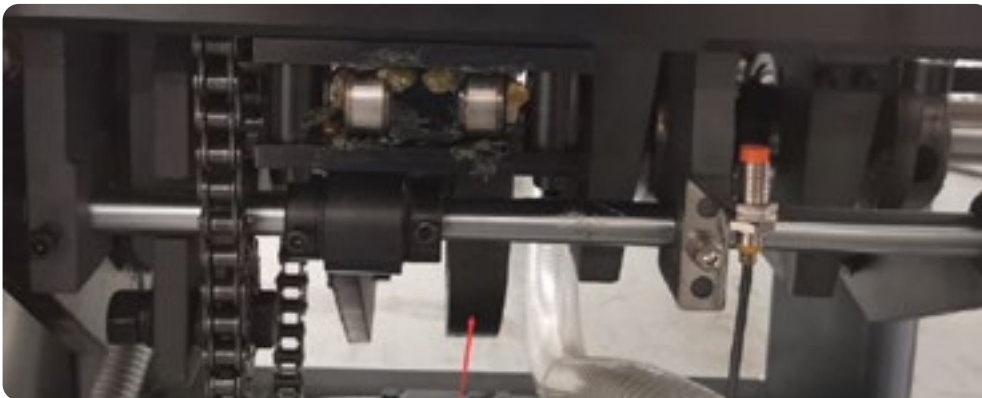

Part Four: Adjust the Cams

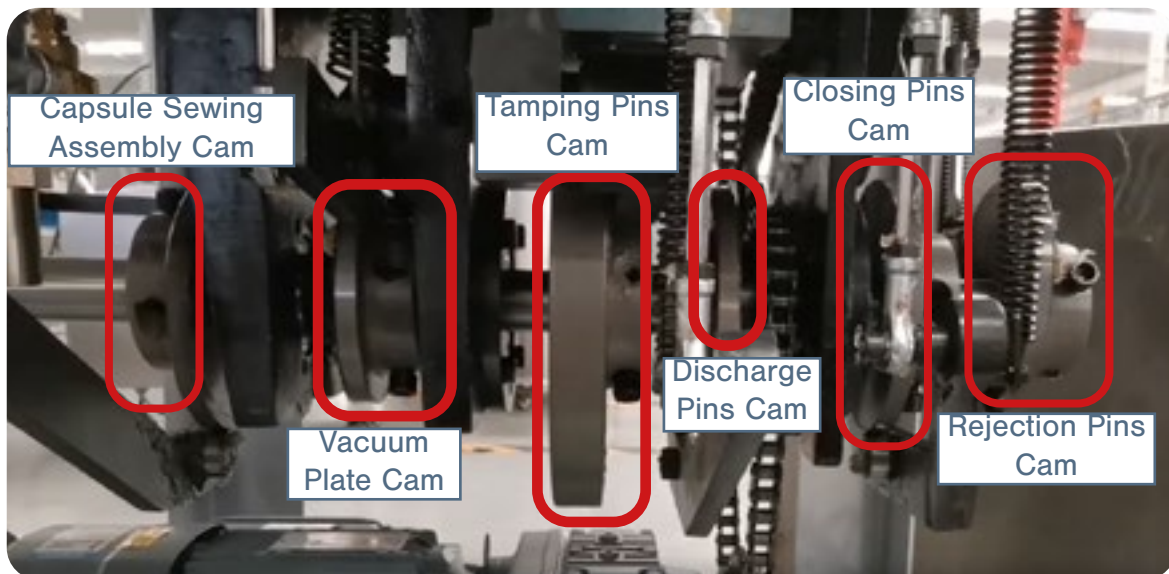

Part Five: Adjust Capsule Sewing Assembly Cam Timing

12. Inch the machine to find the 2 convex lock screws on the cam and loosen them with an Allen key.

12.1 Note: This process is the same for all of the cams' timing calibration.



13. Continue to inch the machine to find the 2 concave screws and loosen them with an Allen key.

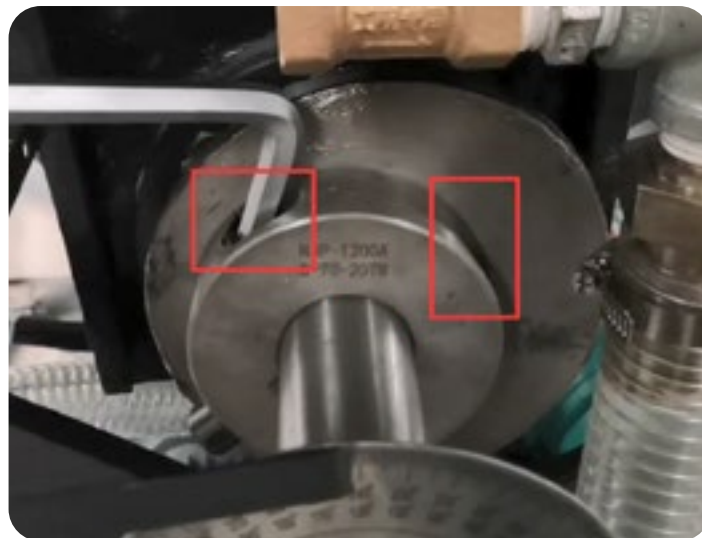

14. Rotate the cam to adjust the position of the capsule fork.

14.1 Note: Ensure that the capsule fork is at its highest point.



15. Once adjusted, hold the cam and secure the convex and concave screws back into the cam with an Allen key.

Part Six: Adjust Vacuum Plate Timing Cam

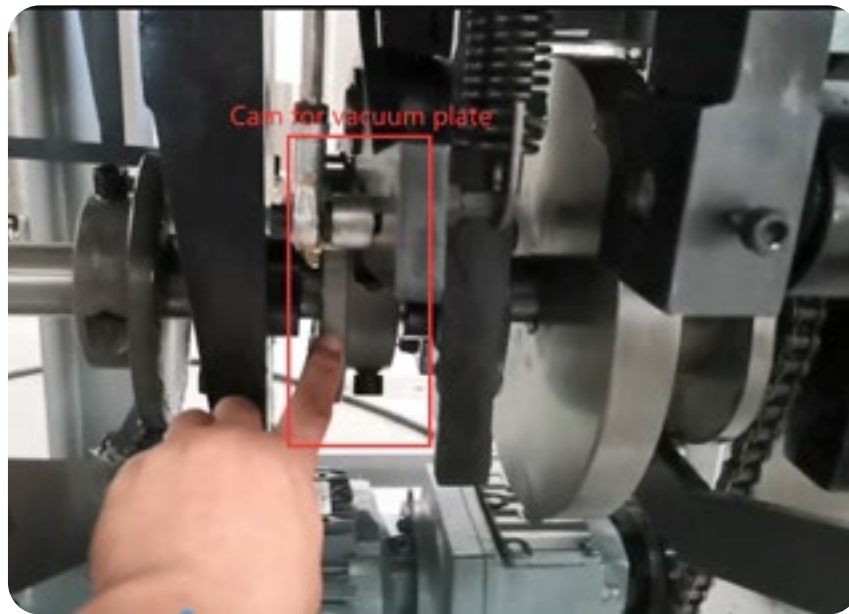

16. Inch the machine to find the 2 convex lock screws on the cam and loosen them with an Allen key.

16.1 Note: This process is the same for all of the cams' timing calibration.

17. Inch the machine to find the 2 concave lock screws on the cam and loosen them with an Allen key.

18. Inch the machine until the segment is right above the vacuum plate.



19. Rotate the cam so that the vacuum plate begins to raise from the lowest point into the die segment.



20. Once the vacuum plate begins to raise, hold the cam and secure the convex and concave screws back into the cam with an Allen key.

Part Seven: Adjust Discharge Pins, Closing Pins, and/or Rejection Pins Cam Timing

Note: This process works for each cam.

21. Inch the machine so that the segments begin to move.

The Discharge Pins should be closing and the Closing Pins and Rejection Pins should be at their lowest points.



22. Find the cam that is out of calibration.

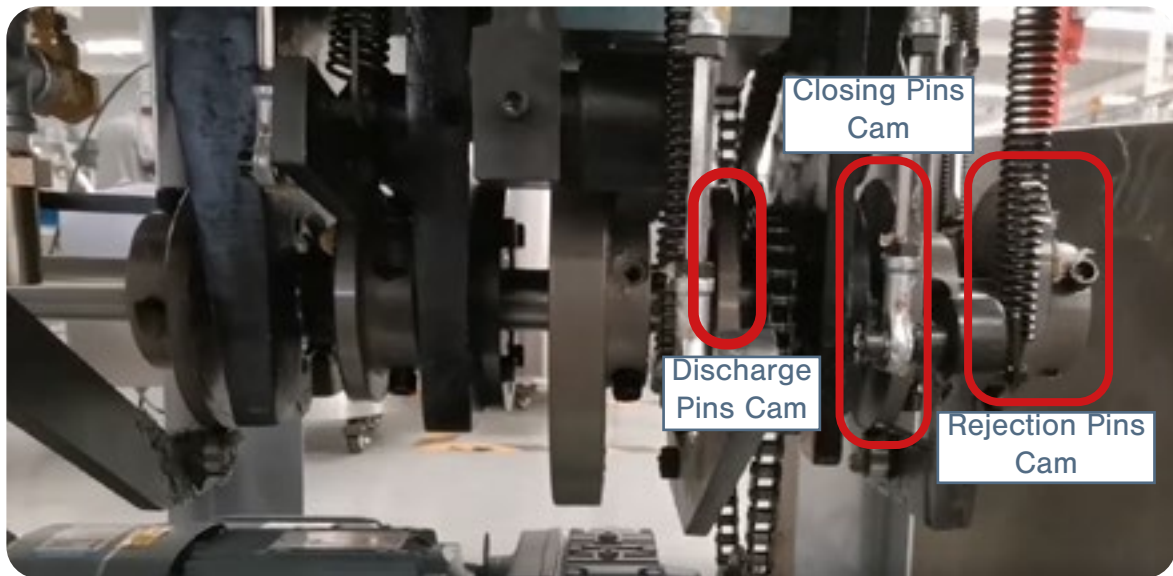

23. Inch the machine to find the 2 convex lock screws on the cam and loosen them with an Allen key.

24. Inch the machine to find the 2 concave lock screws on the cam and loosen them with an Allen key.

25. Inch the machine to move the segments.

26. Rotate the cam until the Discharge Pins/Closing Pins/Rejection Pins reach the lowest point.

26.1 Note: Photo below is of the Discharge Pins.



27. Once the Discharge Pins/Closing Pins/Rejection Pins are at their lowest point, hold the cam and secure the convex and concave screws back into the cam with an Allen key.

Maintenance

To ensure that the FAF 3500® will have a long operational life, maintenance is essential. This section includes methods for replacing parts, troubleshooting solutions, and how often to grease and clean your machines to keep its performance optimal.

General Maintenance Prescriptions

- Use the maintenance checklist (found in the Appendix) before, during, and after machine operation.
- Make sure all grease points are maintained and regularly lubricated.
- Use an appropriate amount of lubricant. Excess grease can drip into the capsules.
- Before reassembling the machine after cleaning, make sure that the parts are dried and oiled.
- Constantly check for any loose nuts and/or screws before, during, and after machine operation.
- If the machine is not used for more than a week, place the Tooling in a container and cover in lubricant.

Lubrication

Regularly greasing your machine is vital to prolonging its operational life. Parts that are not greased properly can make the machine seize up and cause major problems later. LFA Machines recommends maintaining a lubrication schedule for your FAF 3500®, which can be found in this section.

Tools and Materials Needed

- Hydraulic oil ISO VG 46 (use H1 NSF for food grade products)
- NLGI grade 1 grease (use H1 NSF for food grade products)
- Set of metric Allen keys with ball ends
- Disposable latex/rubber gloves (for food grade products and to protect hands from grease)
- Hairnet and/or beard net (food grade products only)
- Sterile shoe covers (food grade products only)



WARNING: To prevent any potential personal injury, unplug the FAF 3500® from the electrical outlet.

Instructions

Note: Wear latex/rubber gloves (and appropriate food grade attire if applicable) during this process.

1. Apply one layer of grease onto the work surface of the cams and rollers.
 - 1.1 Note: To see drawings of lubrication point locations, please refer to the Lubrication Schedule on page 42.
2. Apply lubrication oil to joint bearings, sealing bearings, and sliding guides.
3. Grease the ball bearings, needle bearings, and linear bearings.
4. Check the driving chains' tightness and apply lubricant.
5. Replenish the oil of the main driving and feeder decelerators.
6. Replenish oil of the Main Turret and Tamping Section transfer cases.

Lubrication Schedule

LFA Machines recommends the following FACF® range parts to be lubricated according to the following frequency:

Location	Parts	Image	Frequency	Type of Lubricant
Driving Part Assembly	<ul style="list-style-type: none"> Chain 		Visually inspect chain and apply when dry (approximately weekly).	Oil or grease
Rejection Driving Assembly	<ul style="list-style-type: none"> Cam bearing Needle bearing 		<p>Visually inspect bearings and apply when dry (regularly).</p> <p>Visually inspect cam and apply when dry (weekly).</p>	NLGI Grade 1
Press Driving Assembly	<ul style="list-style-type: none"> Cam bearing Needle bearing Cam 		<p>Visually inspect bearings and apply when dry (regularly).</p> <p>Visually inspect cam and apply when dry (weekly).</p>	NLGI Grade 1
Main Shaft Support Assembly	<ul style="list-style-type: none"> Deep groove ball bearing 		Visually inspect bearings and apply when dry (regularly).	NLGI Grade 1
Capsule Separation, Powder Press, Magazine Drive Assembly	<ul style="list-style-type: none"> Needle bearing Cam Cam bearing 		<p>Visually inspect bearings and apply when dry (regularly).</p> <p>Visually inspect cam and apply when dry (weekly).</p>	NLGI Grade 1
Dosing Driving Assembly	<ul style="list-style-type: none"> Cam bearing Cam 		<p>Visually inspect bearings and apply when dry (regularly).</p> <p>Visually inspect cam and apply when dry (weekly).</p>	NLGI Grade 1

Location	Parts	Image	Frequency	Type of Lubricant
Powder Press Guide Assembly	<ul style="list-style-type: none"> Deep groove ball bearing Rod end bearings 		<p>Visually inspect bearings and apply when dry (regularly).</p> <p>Visually inspect cam and apply when dry (weekly).</p>	NLGI Grade 1
Turntable Assembly	<ul style="list-style-type: none"> Deep groove ball bearing Linear bearings Cam bearing Disk cam 		<p>Visually inspect bearings and apply when dry (regularly).</p> <p>Visually inspect cam and apply when dry (weekly).</p>	NLGI Grade 1
Top of Powder Hopper	<ul style="list-style-type: none"> Feeding decelerator 		<p>Visually inspect and replenish when necessary. Replace entirely once every 6 months.</p>	Hydraulic oil ISO VG 46 (H1 NSF for food grade products)
Inside Machine Body near Motor	<ul style="list-style-type: none"> Main drive decelerator 		<p>Visually inspect and replenish when necessary. Replace entirely once every 6 months.</p>	Hydraulic oil ISO VG 46 (H1 NSF for food grade products)
Inside Machine Body Underneath the Main Turret	<ul style="list-style-type: none"> Transfer case for Main Turret 		<p>Visually inspect and replenish when necessary. Replace entirely once every 6 months.</p>	WA 460 Oil
Inside Machine Body Underneath the Tamping Section	<ul style="list-style-type: none"> Transfer case for Tamping Section 		<p>Visually inspect and replenish when necessary. Replace entirely once every 6 months.</p>	WA 460 Oil

Dismantling for Repair and Replacement

Eventually due to wear and tear, some parts of the FACF 3500® range will need to be removed for repair and replacement. To prevent any delays in your capsule production, it is best practice to keep extra parts just in case.

To buy a FACF 3500® range part replacement, simply go to lfacapsulefillers.com/products/machine-spare-parts/facf-range-spare-parts

Warranty

To access our warranty policy, go to lfacapsulefillers.com/warranty

If your part is eligible for warranty, have your part's serial number on hand and please contact LFA Machines:

USA

Phone

+1 (682) 312-0034

Email

support.usa@lfamachines.com

UK

Phone

+44 01869 250234

Email

support.uk@lfamachines.com

Taiwan

Phone

+886 422031790

Email

support.asia@lfamachines.com



WARNING: To prevent any potential personal injury, ALWAYS unplug the FACF 3500® from the electrical outlet when replacing parts.

Wear Parts and Causes of Damage

Wear Part	Cause of Damage
Capsule Holding Pins	The Capsule Holding Pins are an integral part of the capsule sowing section. They hold the capsules in the cartridge and time their release. They can become damaged in the event of a jam, during cleaning, or if mishandled.
Bearings for Capsule Segment	Behind the casing to the capsule sewing section, there are 8 bearings that are used to maintain a smooth back/forward and up/down motion to orient and sew the capsules.
Plastic Inserts for Capsule Segment	The capsule segments rotate the Turret and are facilitated by plastic inserts. These segments can become worn, which can cause fine powder to leak.
Tamping Pins	The tamping pins are used to create the slug that is pushed into the body of the capsule before the cap is applied. Tamping pins might need replacing in the event of a hard stop or the product is seriously caustic or abrasive.
Tamping Pin Springs	The tamping pin springs are retained to the tamping pins. Over time these springs will go through a large amount of compressions and can lose their ability to hold the pins in the tamping pin blocks, which can affect capsule weights and protection in the event of a jam.
Dosing Disk Wear Ring	As the Dosing Disk rotates to create the slugs, it turns over the wear ring. This part is not only designed to help facilitate the movement of the Tamping Station, but also gives a flat surface for the slug to be formed against. Because of these two functions, the Dosing Disk will wear down over time.
Capsule Ejection Springs	The capsule ejection springs are used to direct the capsules as they are pushed out of the machine. Sometimes they can become bent during cleaning or maintenance.

Tooling

If you want to change the size of a capsule, it is necessary to change the Tooling.

To buy new Tooling from LFA Machines, simply go to lfacapsulefillers.com/fac-range-plates-moulds-set

To watch a video of an FACF® Range Tooling change, go to lfacapsulefillers.com/videos/fac-capsule-filler-tooling-change

Tools and Materials Needed

- Set of metric Allen keys with ball ends
- Metric wrench set with sockets
- New Tooling
- Tooling Calibration Set from FACF® Range Toolkit
- Rubber mallet
- Crosshead screwdriver
- Empty capsules suited for new Tooling
- Disposable latex/rubber gloves (for food grade products and to protect hands from grease)
- Hairnet and/or beard net (food grade products only)
- Sterile shoe covers (food grade products only)



WARNING: To prevent any potential personal injury, ALWAYS unplug the FACF 3500® from the electrical outlet when replacing parts.

Instructions

Note: Wear latex/rubber gloves (and appropriate food grade attire if applicable) during this process.

Part One: Changing the Capsule Die Segments

1. Open the Perspex Casing's doors.
2. Remove the two bolts and small metal plate with a wrench and remove the Capsule Closing Plate.



3. Remove the top section of the Tooling's two bolts with a wrench.

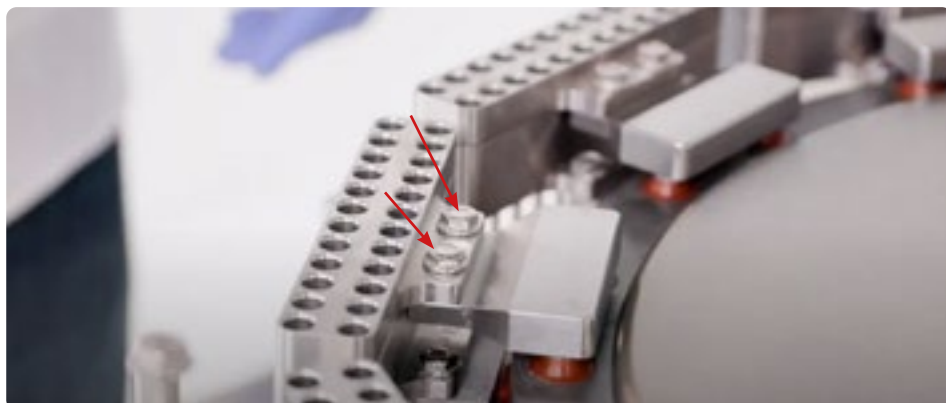

4. Take off the top section of the Tooling and set aside.

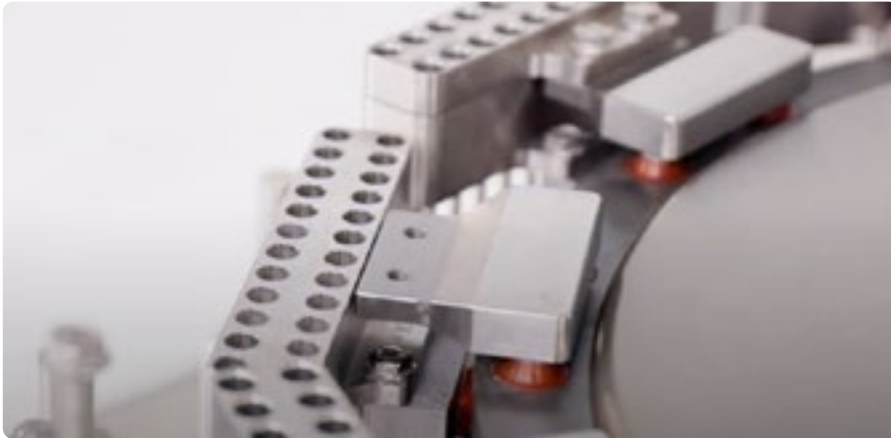

5. Remove the two bolts on the bottom section of the Tooling with a wrench.

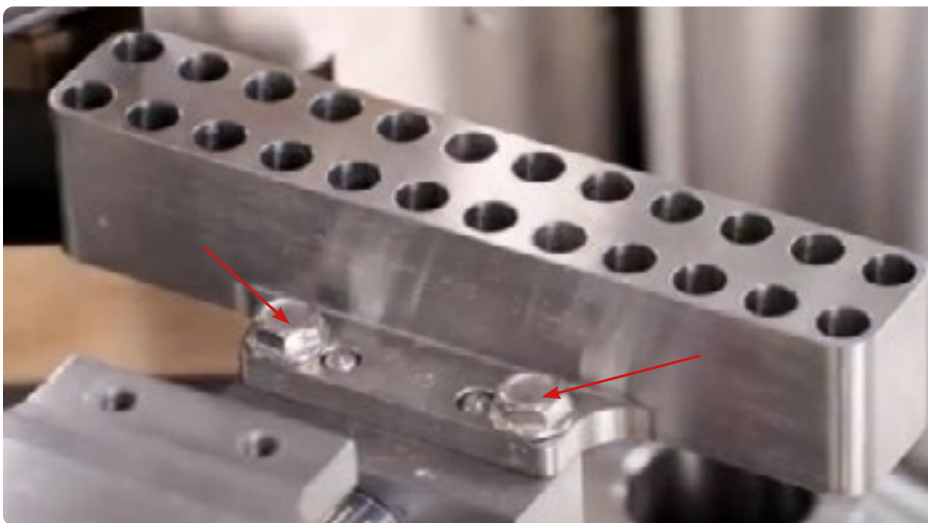

6. Take off the bottom section of the Tooling and set aside.

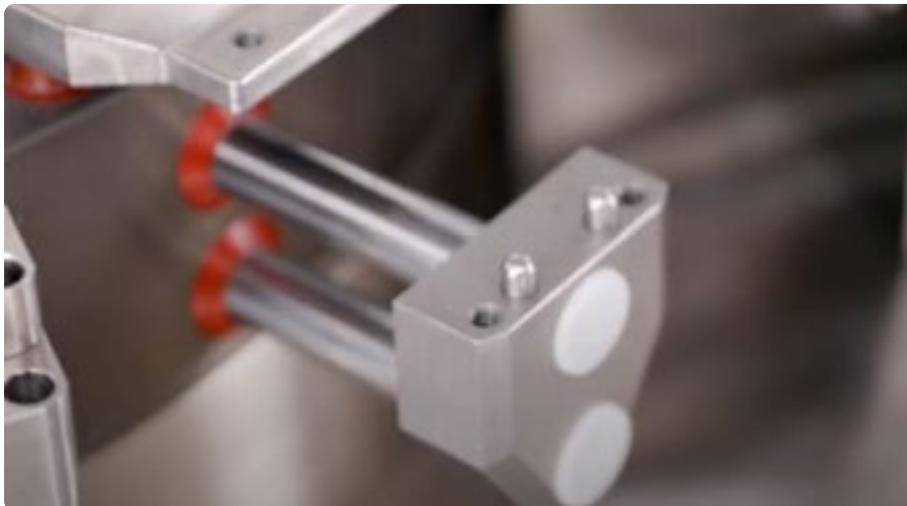

7. Manually operate machine until the next set of the Tooling sections are accessible.

8. Repeat steps 2-7 until all Tooling sections are removed.

9. Insert one of the new bottom sections of Tooling onto the Turret and tighten its bolts with a wrench.



10. Place one of the new top sections of the Tooling under the lip of the Turret chamfer side up and loosely tighten its bolts by hand.

10.1 Note: The bolts should be finger tight so that the new top section can still move.

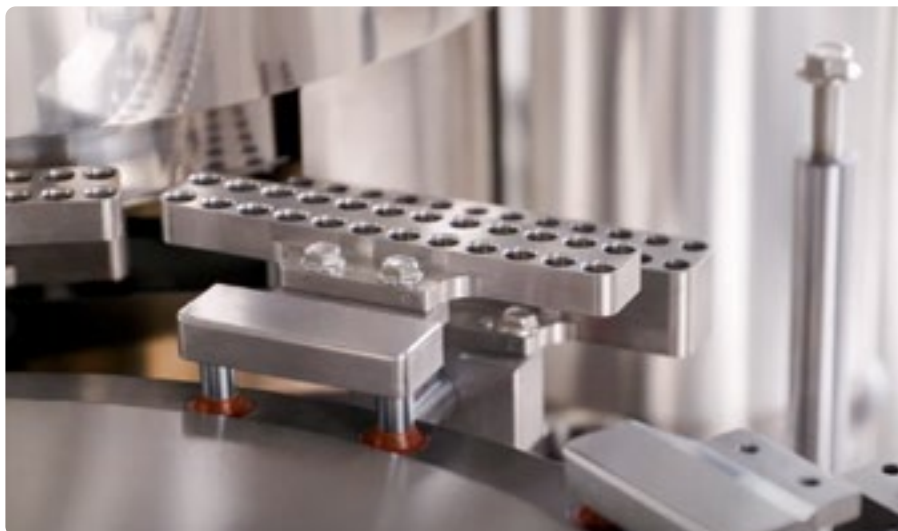

11. Rotate the machine so that the new Tooling is at the next station.

12. Insert the alignment tools from the Tooling Calibration Set into the two end slots of the Tooling.



13. Tighten the new top section of the Tooling with a wrench with the alignment tools still in place.

13.1 Note: Tighten the bolts slowly and in small increments. While tightening, occasionally lift the Alignment Tools and rotate them inside the new Tooling to ensure they are in the correct position.

14. Repeat steps 9-13 until all of the new Tooling sections are installed.
15. Place the metal plate and Capsule Closing Plate back onto the Turret.
 - 15.1 Note: Ensure that the chamfered edge is facing down and the Capsule Closing Plate is covering the Tooling.
16. Tighten the Capsule Closing Plate's bolts finger tight first, then equally tight with a wrench.



Part Two: Capsule Sewing Section

17. Turn the Capsule Hoppers' door knobs counterclockwise to loosen them.
 - 17.1 Note: The doors will fall down and prevent capsules from falling out.



18. Remove the Capsule Hoppers by loosening their bolts with an Allen key.
18.1 Note: Remove the Capsule Hoppers carefully to not damage the Capsule Magazines' edges.

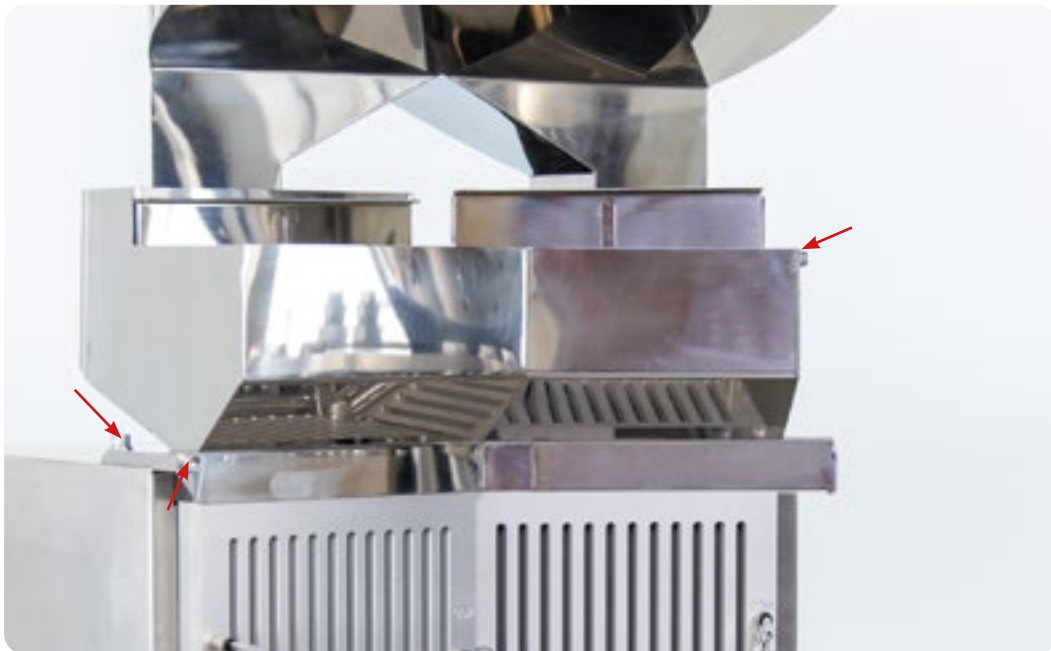

19. Remove the front sections of the Capsule Magazines with an Allen key.
19.1 Note: Keep hold of the front section to ensure it does not fall.

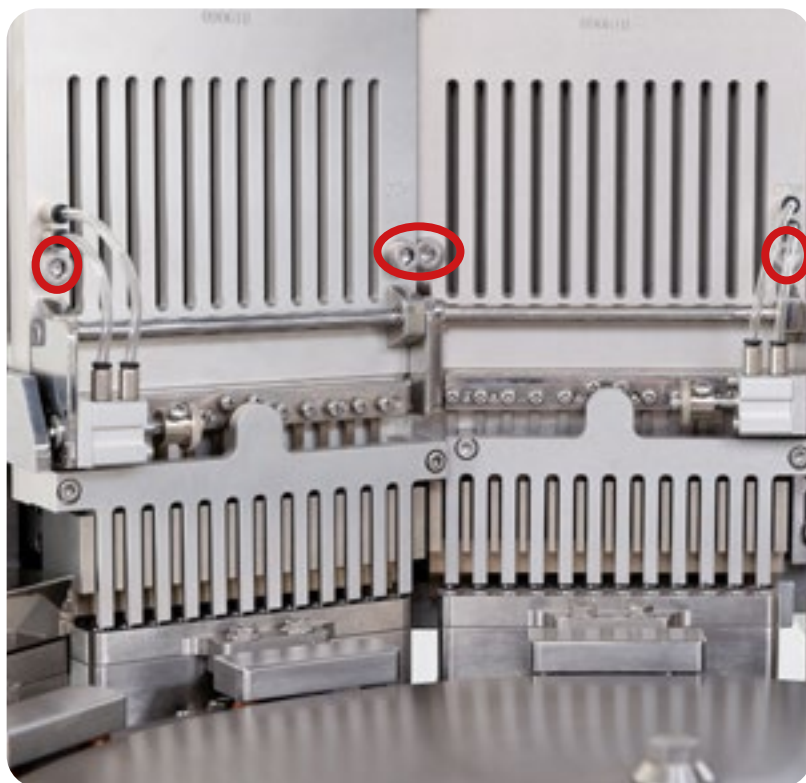

20. Remove the Capsule Magazine's back teeth with an Allen key.



21. Remove the Capsule Magazine's front teeth with an Allen key.



22. Insert the new front teeth onto the Capsule Magazine and tighten its bolts with an Allen key.
22.1 Note: The bolts should be finger tight so that the new back teeth can still move.
23. Insert the alignment tools from the Tooling Calibration Set in the two ends of the new front teeth.
23.1 Note: Ensure that the thicker end of the alignment tools goes into capsule bores first.
24. Adjust the new front teeth according to the alignment tools.



25. Remove the alignment tools from the new front teeth.

26. Manually operate the machine until the block that pushes the back teeth moves furthest forward in the cycle.

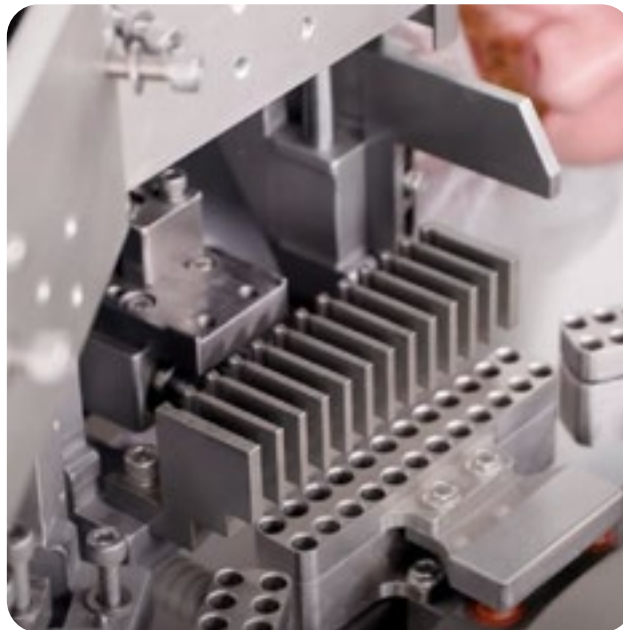

27. Insert the new front teeth into the new back teeth and tighten its side bolts with an Allen key.

27.1 Note: The bolts should be finger tight so that the new front teeth can still move.



28. Insert two empty capsules cap first into the two end slots of the new front teeth.
28.1 Note: Ensure that the capsule cap ends are aligned with the new front teeth.



29. Tighten the new front teeth's bolts with an Allen key in equal and small increments.
29.1 Note: Ensure that the capsules are still aligned while tightening.
30. Manually operate the machine for one rotation.
30.1 Note: If any squeaking or metal-on-metal contact occurs, re-adjust the new front and back teeth.

31. Insert the new front sections of the Capsule Magazines into the new front and back teeth.
32. Loosely tighten the new front sections' bolts to the Capsule Magazines with an Allen key.

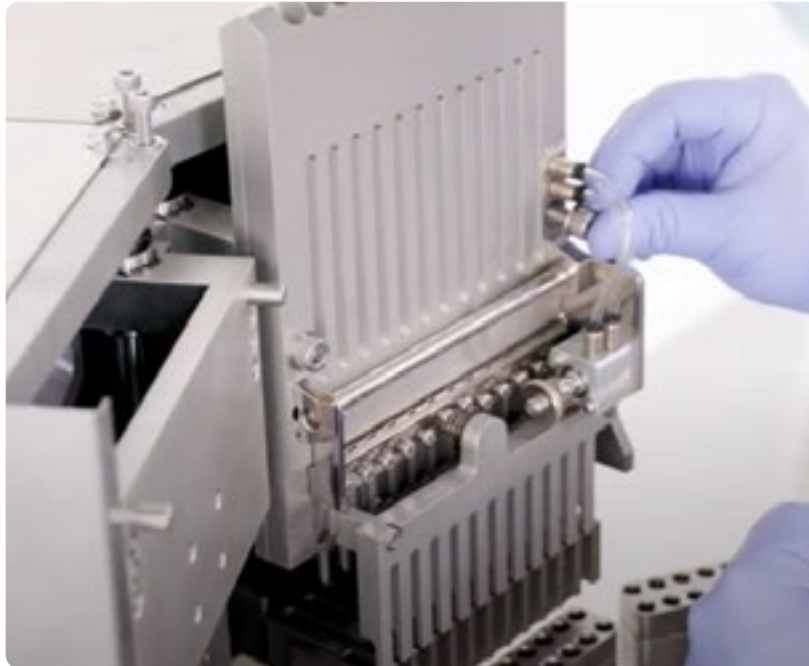

33. Manually operate the machine until the new front sections of the Capsule Magazines drop down to their lowest position.

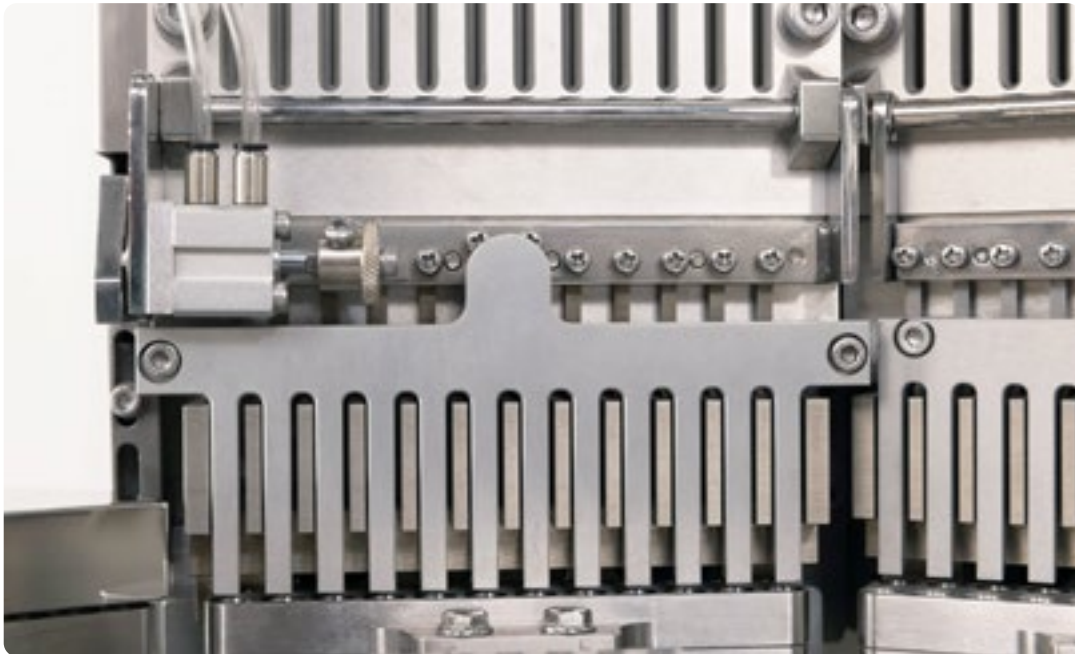

34. Ensure that the gaps between the new front sections and the new front and back teeth have sufficient space and are not causing any metal-on-metal contact.
35. Fully tighten the new front sections' bolts to the Capsule Magazines.
36. Manually operate the machine one more time to ensure that there is no metal-on-metal contact.

37. Re-insert the Capsule Hoppers onto the new Capsule Magazines and tighten their bolts with an Allen key.

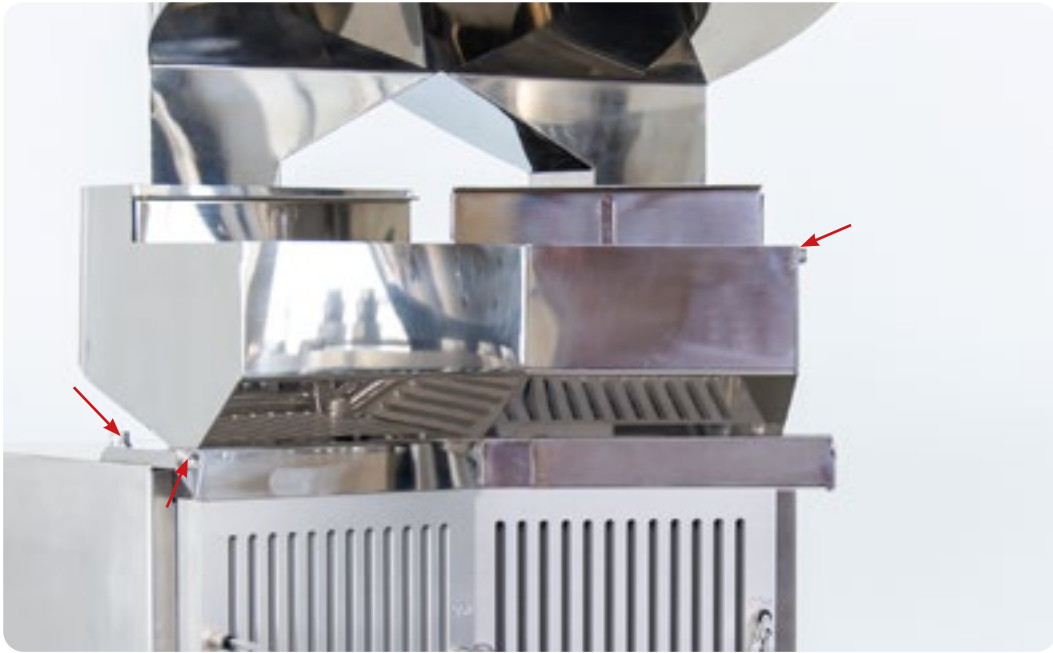

38. Manually rotate the machine one more time to ensure there is no metal-on-metal scraping.

Part Three: Changing the Tamping Turret

39. Open the right panel of the machine and insert the handle to raise the Powder Hopper and Auger's height.

40. Loosen the Powder Hopper's bolts with a wrench and remove the Powder Sensor.

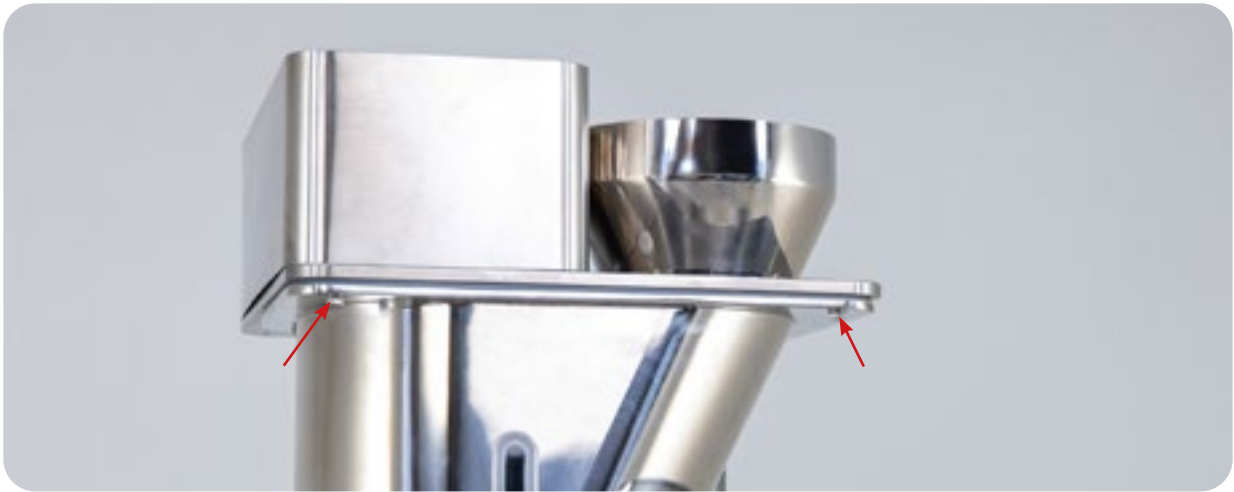

41. Remove the Powder Hopper Auger by shifting it loose.

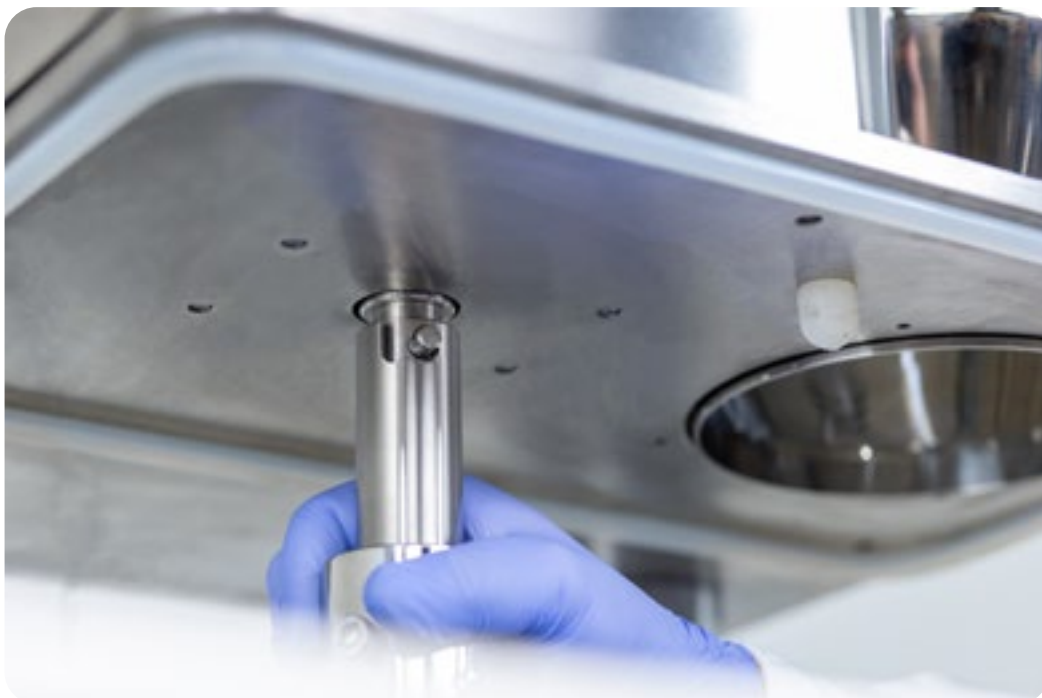

42. Loosen the screws on each of the tamping pin holders to remove the holders.

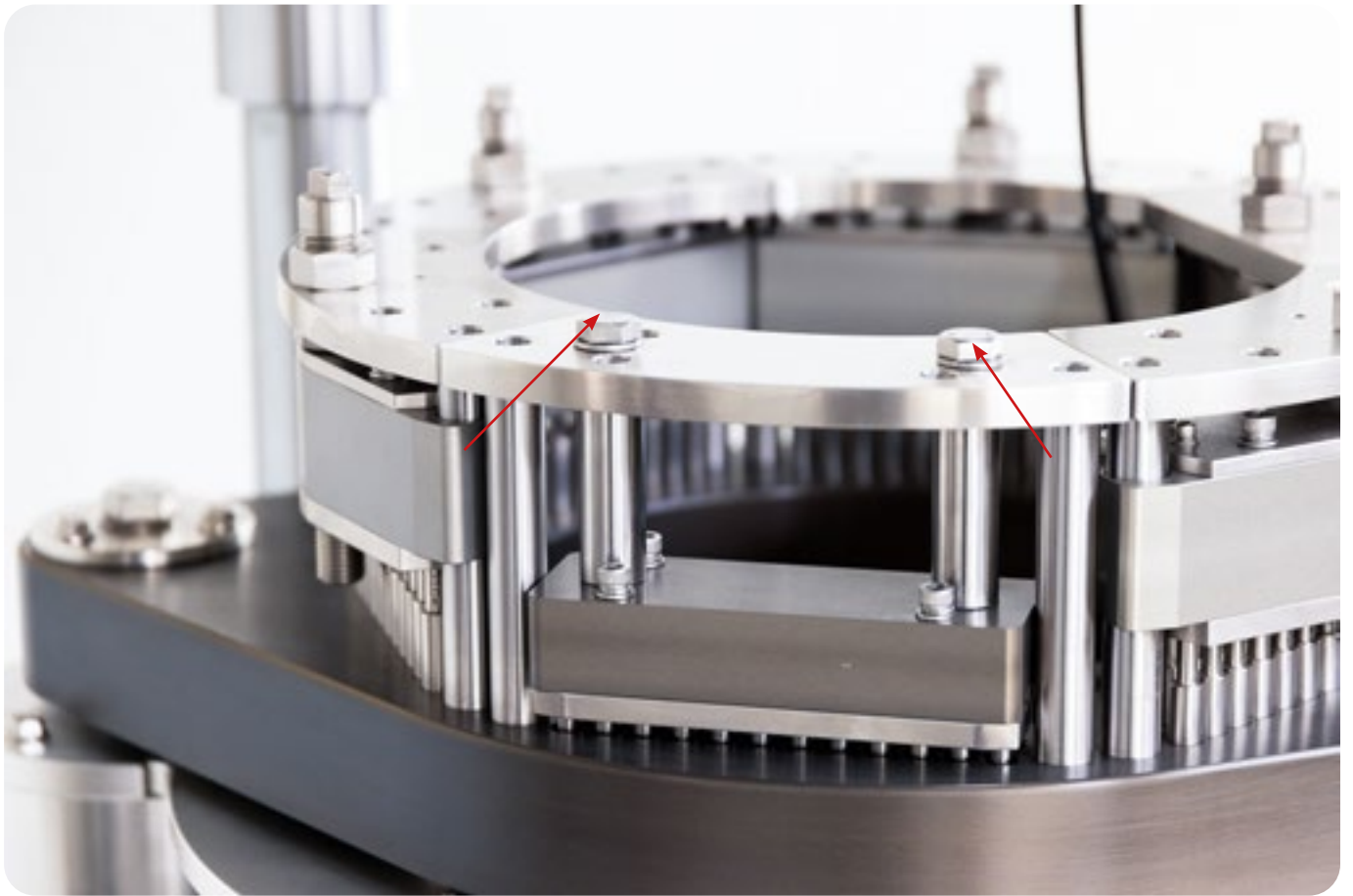

43. Pull up the plastic cover and set it aside.



44. Loosen the two big screws on both sides of the supporting plate to take it off.



45. Loosen the Powder Sensor's bolt with an Allen key to remove and set it aside.



46. Remove the screws of the Dosing Plate and take it off.



47. Remove the bolts on the Tamping Bowl with a socket wrench.

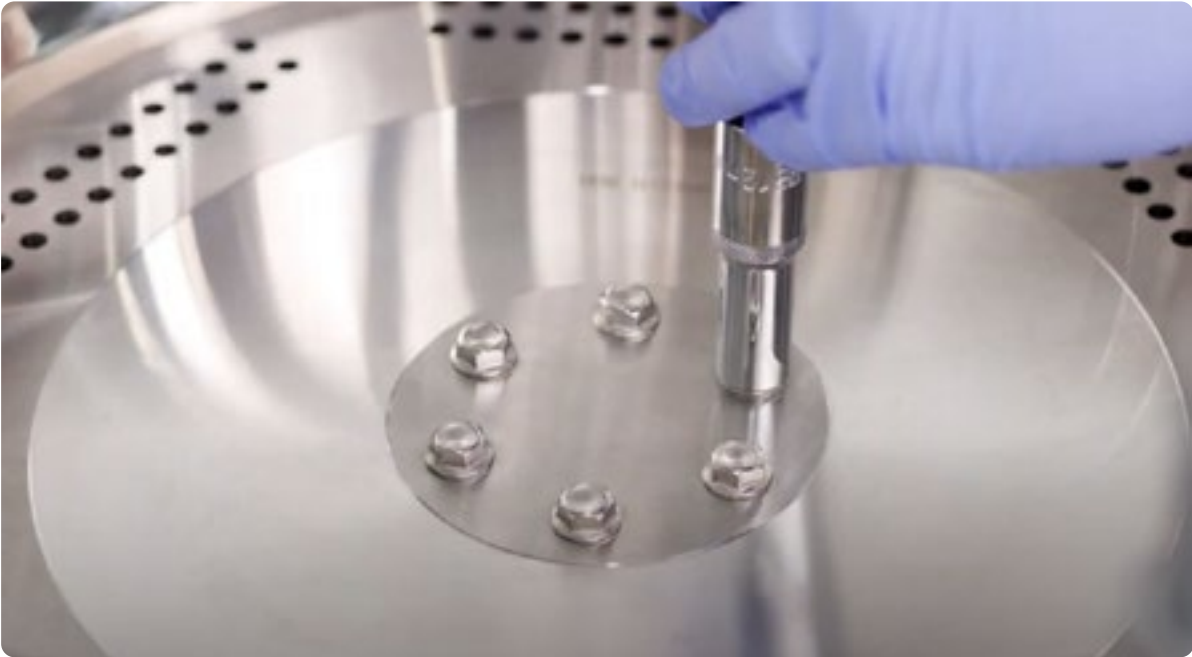

48. Lift up and remove the bottom of the Tamping Bowl with an Allen key.



49. Place the bottom of the new Tamping Bowl onto the machine and loosely tighten the bolts.



50. Place the new Dosing Plate onto the new Tamping Bowl.

51. Re-insert the Powder Sensor and secure its bolt with an Allen key.



52. Fully tighten the four bolts onto the new Dosing Plate of the Tamping Turret.

52.1 Note: Ensure to tighten in small and equal increments.

53. Insert the new middle section of the Tamping Turret onto the new middle plate and use a rubber mallet to secure it.



54. Fully tighten the two bolts on the new middle section of the Tamping Turret.



55. Manually rotate the machine until the Tamping Turret is at its lowest point.

56. Insert the alignment tools from the Tooling Calibration Set into the two ends of the Tamping Turret's new middle section and new Dosing Plate.

56.1 Note: Pull up the Powder Sensor through the new Tamping Turret's middle section.

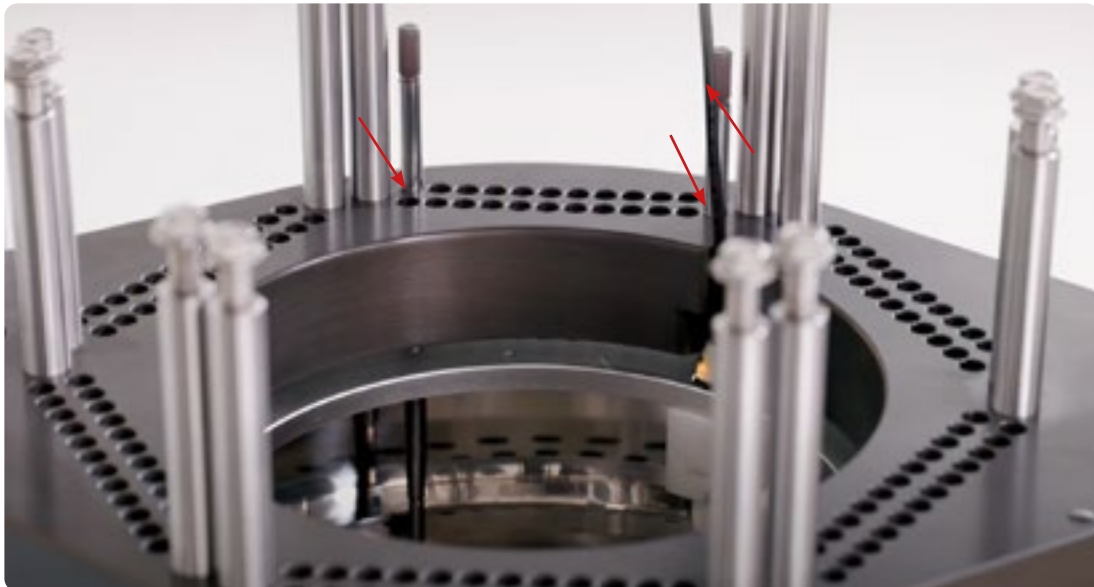

57. Adjust the new bottom of the Tamping Turret so that the alignment tools easily fall in the holes and are able to move freely.

58. Fully tighten the three bolts on the Tamping Bowl with the special tool included with the Toolkit.

58.1 Note: Ensure to tighten the bolts equally and in small increments.

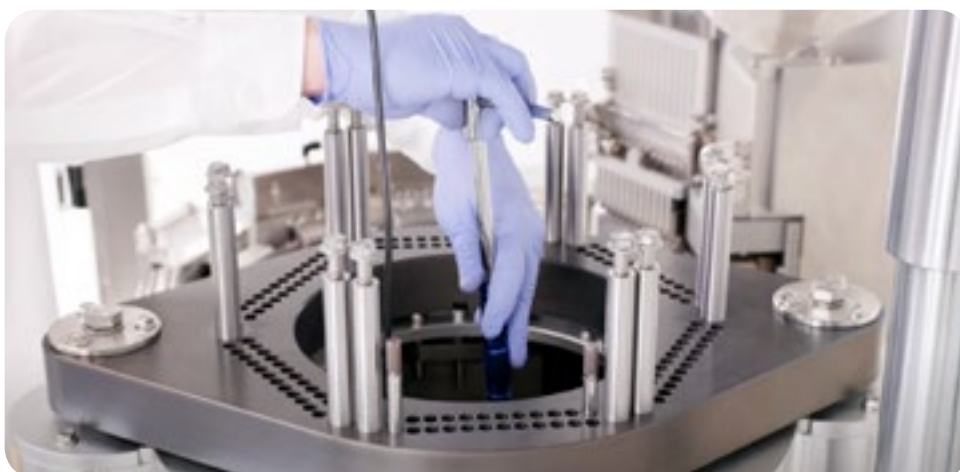

59. Check the alignment tools while tightening the new bottom of the Tamping Turret and make adjustments as necessary.
60. Remove the alignment tools.
61. Insert the capsule slug block into the Tamping Turret.



62. Insert each of the Tamping Pins into their appropriate stations in the Tamping Turret.
62.1 Note: Ensure not to damage the fragile ends.



63. Tighten each of the bolts on top of the Tamping Turret with a wrench.
63.1 Note: Ensure to tighten the bolts equally and in small increments.



64. Place the plastic cover back inside the Tamping Turret.



65. Re-secure of the Tamping Bowl cover.



66. Re-insert the Powder Hopper gently.
67. Rotate the top section back over the Powder Hopper.
68. Re-connect the Auger Paddle.



69. Re-secure the Powder Hopper to the top section with a wrench.



70. Lower the Powder Hopper into the Tamping Turret and through the plastic cover.



71. Re-insert the Powder Sensor onto the Powder Hopper.

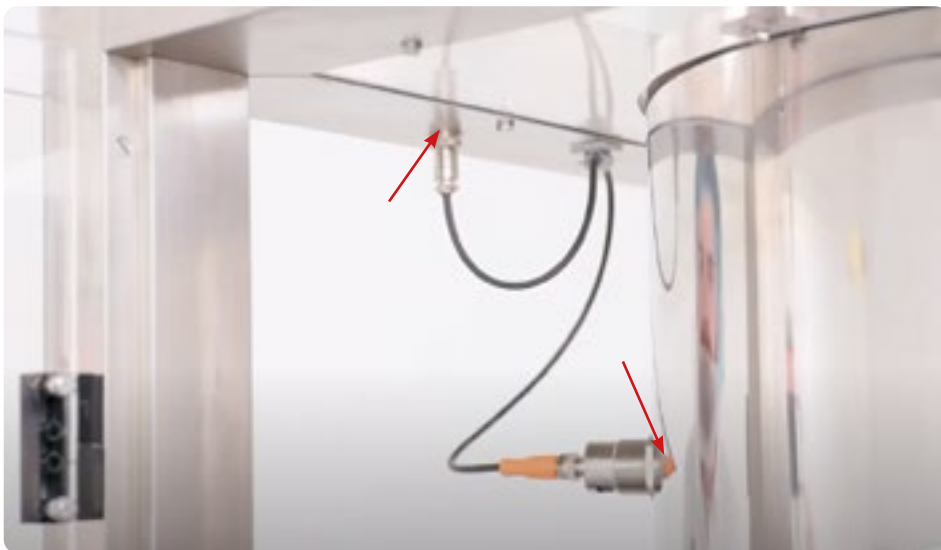

Capsule Holding Pins

The Capsule Holding Pins hold the capsules in the Capsule Magazine and time their release. They can become damaged in the event of a jam, during cleaning, or if mishandled.

Tools and Materials Needed

- Crosshead screwdriver
- Set of metric Allen keys with ball ends
- New Capsule Holding Pins
- Disposable latex/rubber gloves (for food grade products and to protect hands from grease)
- Hairnet and/or beard net (food grade products only)
- Sterile shoe covers (food grade products only)



WARNING: To prevent any potential personal injury, ALWAYS unplug the FACF® from the electrical outlet when replacing parts.

Instructions

Note: Wear latex/rubber gloves (and appropriate food grade attire if applicable) during this process.

Remove the Capsule Holding Pins

1. Turn the Capsule Hopper door's knob counterclockwise to loosen it.
 - 1.1 Note: The door will fall down and prevent capsules from falling out.



2. Remove the Capsule Hoppers by loosening their bolts with an Allen key.
 - 2.1 Note: Remove the Capsule Hoppers carefully to not damage the Capsule Magazines' edges.

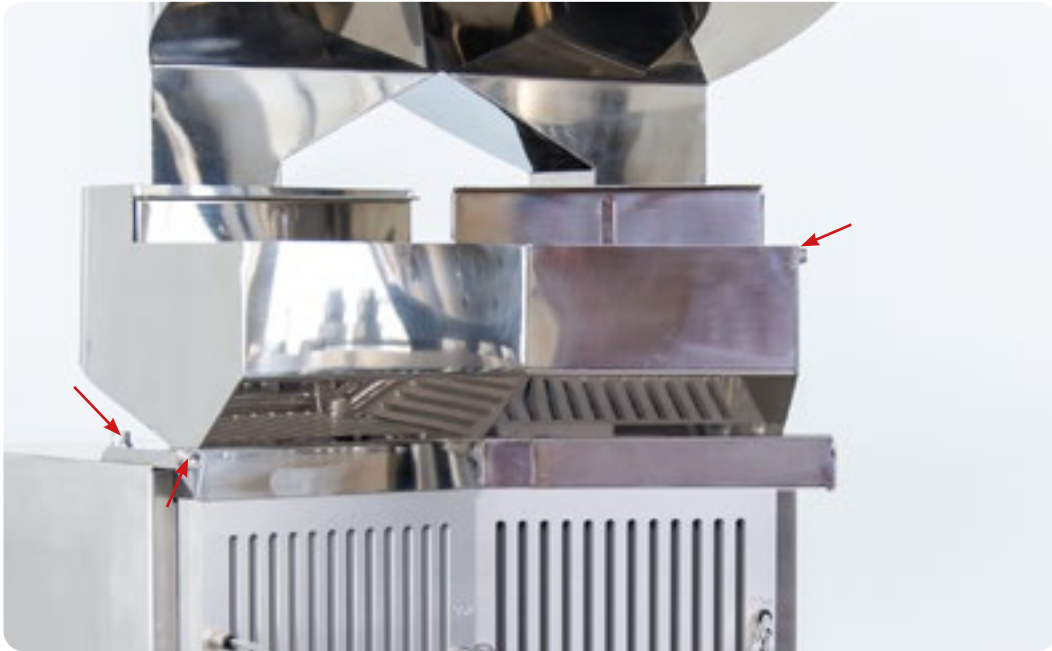

3. Remove the front sections of the Capsule Magazines with an Allen key.
 - 3.1 Note: Keep hold of the front section to ensure it does not fall.

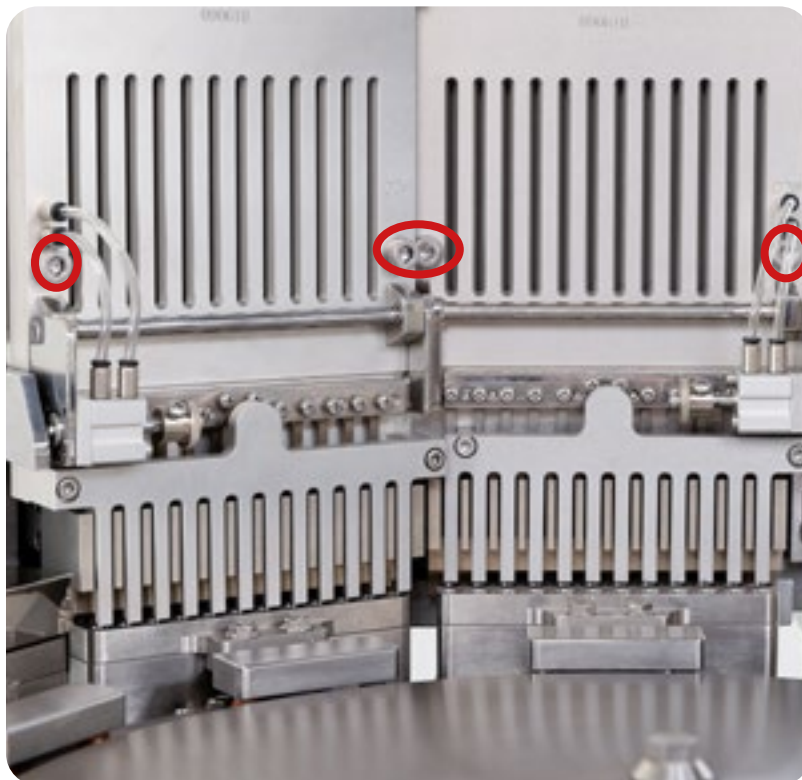

4. Remove each of the screws holding the Capsule Holding Pins with a crosshead screwdriver.



Replace the Capsule Holding Pins

5. Insert the new Capsule Holding Pins into place.
 - 5.1 Note: Ensure that all of the new Capsule Holding Pins are aligned.
6. Secure the new Capsule Holding Pins onto the Capsule Magazine with a crosshead screwdriver.
7. Tighten the side of the Capsule Magazine's screws with a crosshead screwdriver
8. Secure the front section of the Capsule Magazine's screws with an Allen key.
9. Re-insert the Capsule Hopper and tighten its two bolts with an Allen key.

Dosing Disk Wear Ring

As the Dosing Disk rotates to create the powder slugs, it turns over the Dosing Disk Wear Ring. This part not only helps facilitates the Tamping Station's movement, but also gives a flat surface for the powder slugs to be formed against.

Tools and Materials Needed

- Set of metric Allen keys with ball ends
- Metric wrench set
- New Dosing Disk Wear Ring
- Tooling Calibration Set from FACF® Range Toolkit
- Permanent marker
- Crosshead screwdriver
- Disposable latex/rubber gloves (for food grade products and to protect hands from grease)
- Hairnet and/or beard net (food grade products only)
- Sterile shoe covers (food grade products only)



WARNING: To prevent any potential personal injury, ALWAYS unplug the FACF® from the electrical outlet when replacing parts.

Instructions

Note: Wear latex/rubber gloves (and appropriate food grade attire if applicable) during this process.

Remove the Dosing Disk Wear Ring

1. Open the right panel of the machine and insert the handle to raise the Powder Hopper and Auger's height.
2. Loosen the Powder Hopper's bolts with a wrench and remove the Powder Sensor.

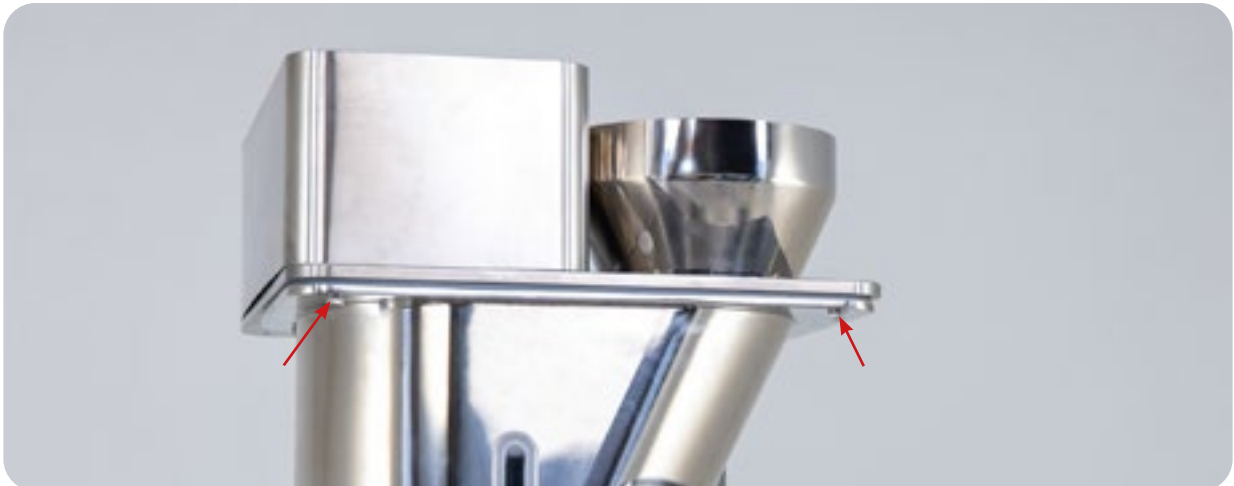

3. Remove the Powder Hopper Auger by shifting it loose.

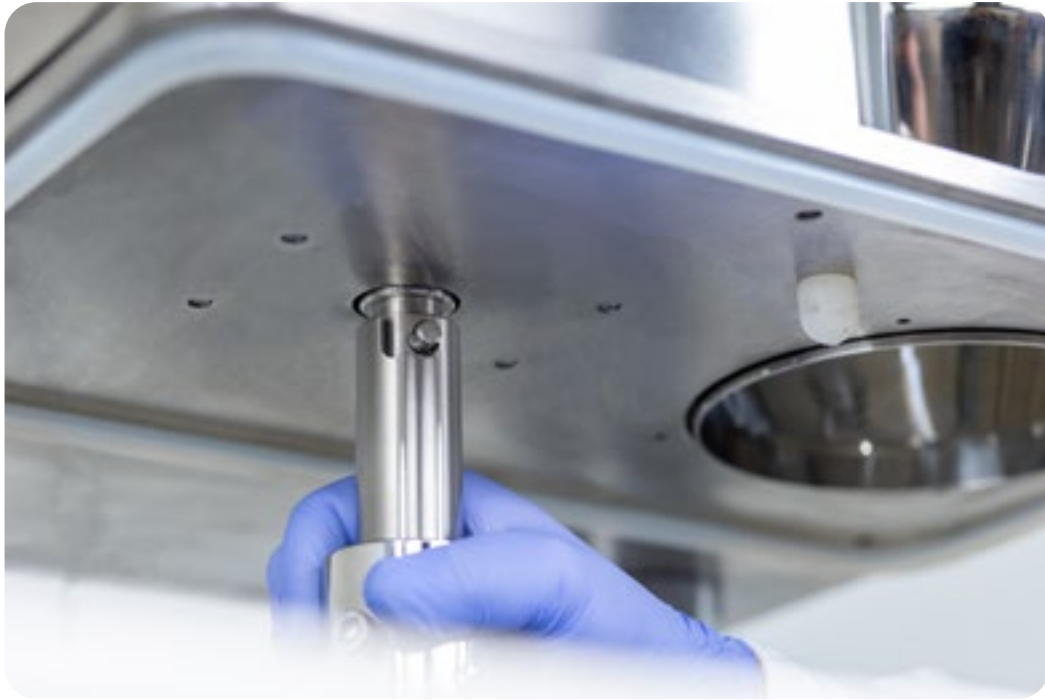

4. Loosen the screws on each of the tamping pin holders to remove the holders.

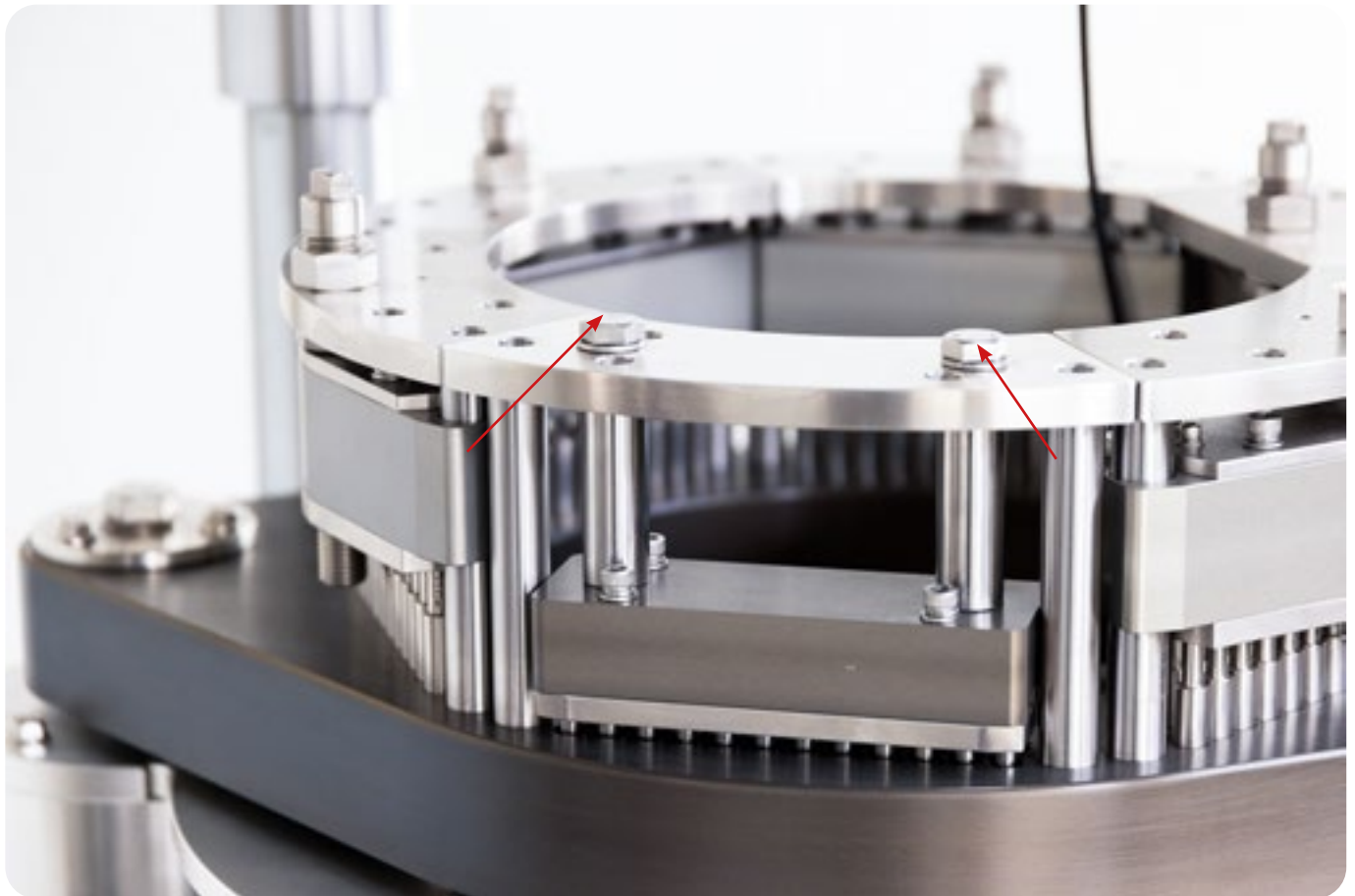

5. Pull up the plastic cover and set it aside.



6. Loosen the two big screws on both sides of the supporting plate to take it off.



7. Loosen the Powder Sensor's bolt with an Allen key to remove and set it aside.



8. Remove the screws of the Dosing Plate and take it off.



9. Remove the bolts on the Tamping Bowl with a socket wrench and lift up and remove it.

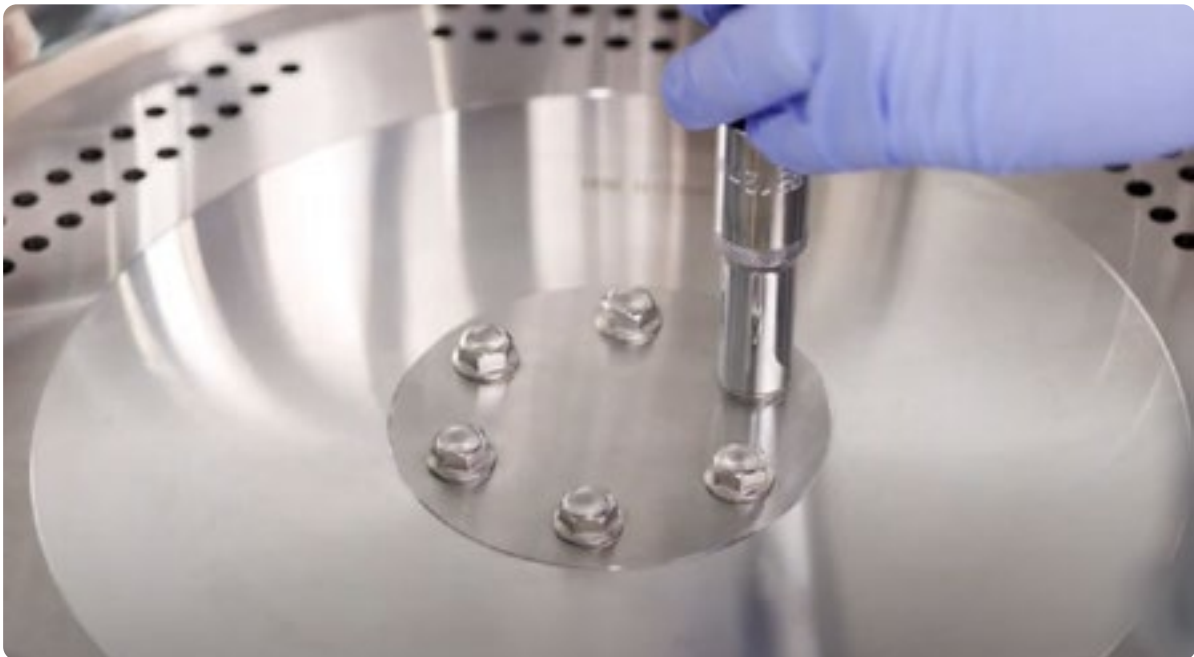

10. Remove the brass Dosing Disk Wear Ring from the machine.



Replace the Dosing Disk Wear Ring

11. Insert the new Dosing Disk Wear Ring onto the bottom of the Tamping Turret.

12. Place the Dosing Plate back onto the new Tamping Bowl.

13. Re-insert the Powder Sensor and secure its bolt with an Allen key.

14. Fully tighten the four bolts onto the Dosing Plate of the Tamping Turret.

14.1 Note: Ensure to tighten in small and equal increments.

15. Insert the middle section of the Tamping Turret onto the middle plate and use a rubber mallet to secure it.

16. Fully tighten the two bolts on the middle section of the Tamping Turret.

17. Insert each of the Tamping Pins into their appropriate stations in the Tamping Turret.

17.1 Note: Ensure not to damage the fragile ends.



18. Tighten each of the bolts on top of the Tamping Turret with a wrench.
18.1 Note: Ensure to tighten the bolts equally and in small increments.

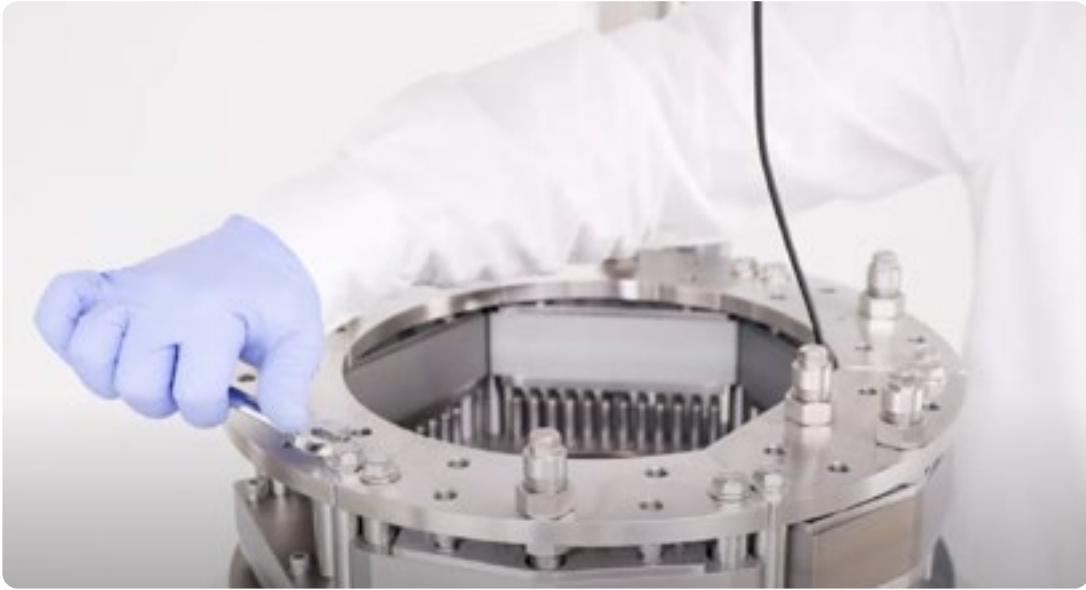

19. Place the plastic cover back inside the Tamping Turret.



20. Re-secure of the Tamping Bowl cover.



21. Re-insert the Powder Hopper gently.
22. Rotate the top section back over the Powder Hopper.
23. Re-connect the Auger Paddle.



24. Re-secure the Powder Hopper to the top section with a wrench.



25. Lower the Powder Hopper into the Tamping Turret and through the plastic cover.



26. Re-insert the Powder Sensor onto the Powder Hopper.



Troubleshooting

Sometimes unavoidable issues will occur while operating the FACF 3500®. Fortunately, there are several methods to remedy these issues.

Common Issues

Symptom	Possible Cause	Possible Solution
Blockage in Capsule Magazine	The capsules are too big or deformed.	Ensure that the capsules fit the Capsule Magazine.
	The Capsule Magazine is jammed.	Clean the Capsule Magazine tracks.
	Something is stuck in the Capsule Magazine's tracks.	Use sandpaper to polish the tracks and/or clean the tracks.
Capsule caps and bodies do not separate	The upper and lower Capsule Die Segments are not in alignment.	Adjust the position of the segments with the alignment tools.
	The Capsule Die Segments are blocked.	Clean the segment holes.
	The vacuum pressure is not high enough, the pipe line is jammed, or there is an air leakage.	Ensure that the vacuum pressure is -0.06 Mpa. Check the vacuum pipes and clean the filter.
The capsule's ends are being punched through	The upper and lower Capsule Die Segments are not in alignment, or the Capsule Closing Plate is too high at the closing station.	Check the closing station and the alignment of the upper and lower Capsule Die Segments with the alignment tools.
	The Closing Pins' position is too high.	Adjust the height of the Pushing Rod.
The machine suddenly stops while running	The powder has run out.	Add more powder.
	The powder's exit is blocked.	Clear the powder's exit and remove any solids from the powder.
	Some parts of the mechanical gear may be loose or damaged, or the electric motor is overloaded.	Check the machine for any damaged or loose parts. If the electric motor is overloaded, repair and adjust accordingly.
The vacuum breaker keeps tripping	The vacuum is being overworked.	Adjust the breaker with a crosshead screwdriver to slightly raise the amps. Clean the vacuum filter and empty the vacuum bag.

Common Issues Continued

Symptom	Possible Cause	Possible Solution
No powder feeding during automatic operation	The powder height sensor of the feeder motor is damaged.	Check the sensitivity of the sensor, clean its switch, and/or adjust the sensor.
	The electrics are bad.	Check the corresponding electric circuit by referring to the electrical diagrams found in the Appendix. Contact an electrician if damaged.
Capsules are not closing	The gap of the Capsule Closing Plate is too high.	Ensure that the gap is 0.2 mm-0.3 mm.
	The powder is too fluffy, so the powder slugs are too big for the capsules.	Granulate the powder.
Filled capsules discharge unsmoothly	The capsules contain static electricity.	If there are capsules stuck to the Discharge chute, blow them off with an air compressor.
	There is a jam in the Discharge chute.	Clean the Discharge chute.
	The angle of the Capsule Closing Plate elevation is too high.	Adjust the screws to reduce the angle.
	Capsules require assistance from an air compressor.	Connect an air compressor to the capsule ejection area. The PSI recommended is 0.4 MPa.
Capsules are not being sewn into the Tooling	The bearing and spring inside the Capsule Gate's channel is covered with powder.	Take off the Capsule Gate, remove its set screw, spring, and ball bearing. Clear the channel of any powder and clean the spring and ball bearing.
Powder is accumulating inside the Die Segment Turret	The powder is not granulated well.	Granulate the powder before filling capsules.
	Powder is overflowing the Upper and Lower Die Segments.	Reduce the machine operation speed, reduce the fill amount and/or change to a larger capsule size.
	The Die Segment Turret has not been cleaned.	Empty the powder collector underneath the Die Segment Turret and run the vacuum cleaner.
Capsules are piling up inside the machine	Capsules are not exiting the Discharge chute.	Attach an air compressor to the 8 mm push fitting underneath the capsule ejection assembly to help the capsules move in the correct direction and down the chute.

Common Issues Continued

Symptom	Possible Cause	Possible Solution
Dents and pin holes in capsules	The capsules are being overfilled.	Use larger capsules.
		Use less powder.
	The capsules have been exposed to moisture.	Improve capsule storage conditions.
	The pin sizes are incorrect or installed incorrectly.	Replace the Tooling or reinstall the pins.
Telescoped capsules	Machine components are not installed correctly or worn out.	Adjust or replace the worn out components.
	The capsule fill weight is too high.	Lower the capsule fill weight.
	The capsules' storage area experiences variation in temperature.	Store the capsules in an area with a consistent temperature.
Improperly closed capsules	There is damage to the body-cap interface (sealing area).	Replace the damaged capsules.
	The capsules are being overfilled.	Use larger capsules.
		Use less powder.
Dusty capsules	Capsules are not being polished.	Use a capsule polisher after filling capsules. Order one from LFA Machines at lfacapsulefillers.com/cp-7000-capsule-polisher
Cracked capsules	The capsules have been exposed to moisture.	Improve capsule storage conditions.
	The Capsule Die Segments are misaligned.	Adjust the Capsule Die Segments.
	The pin sizes are installed incorrectly.	Re-install the pins.

De-Jamming the FACF® Range

There are a couple reasons why a FACF 3500® might jam such as:

- Disfigured capsules become lodged in magazine tracks.
- Powder builds up.

The methods that can fix a jammed FACF® follow below:

Tools and Materials Needed

- Set of metric Allen keys with ball ends
- Crosshead screwdriver
- Cleaner (e.g. Member's Mark Commercial Lemon Fresh Disinfectant)
- Sanitizer (e.g. Member's Mark Commercial Sanitizer)
- Clean cloths and a toothbrush
- Dry raw powder materials
- Disposable latex/rubber gloves (for food grade products and to protect hands from grease)
- Hairnet and/or beard net (food grade products only)
- Sterile shoe covers (food grade products only)



WARNING: To prevent any potential personal injury, ALWAYS unplug the FACF 3500® before de-jamming it.

Instructions

Note: Wear latex/rubber gloves (and appropriate food grade attire if applicable) during this process.

Method 1: Dislodge Disfigured Capsules

1. Remove the Capsule Hopper and the Capsule Magazine with a wrench.
 - 1.1 Note: Please refer to the remove and replace Capsule Holding Pins instructions on page 67 for further information.
2. Take apart the Capsule Magazine with an Allen key and remove any stuck/damaged capsules.
 - 2.1 Note: Please refer to the remove and replace Capsule Holding Pins instructions on page 67 for further information.





Method 2: Clean Excess Powder Buildup

1. Remove the Powder Hopper, Auger, and each part of the tamping Tooling.
 - 1.1 Note: Please refer to the remove and replace Tooling instructions on page 46 for further assistance.
2. Take one of the parts removed from the machine and sanitize it with a clean cloth.
 - 2.1 Note: To ensure that all dirt and debris are removed, clean one part at a time.
3. Take a clean cloth and carefully wash the part thoroughly.
 - 3.1 Note: Use the toothbrush for difficult-to-remove debris. When cleaning Tooling, use non-abrasive cleaning equipment such as a soft pipe cleaner and soft cloth.
4. Ensure that the part is dry.
5. Repeat steps 2-4 for each remaining part until they are all clean.

Cleaning

During the FACF 3500®'s operation, excess powder will find its way into parts of the machine, particularly in the Capsule Magazine and Tamping Turret. It is important to clean the FACF 3500® thoroughly to prevent rusting and cross contamination.

LFA Machines recommends that the machine be cleaned after each operation.

Tools and Materials Needed

- Cleaning brush/paintbrush
- Bagless vacuum
- Long wire pipe cleaner
- Toothbrush
- Alcohol-based sanitizer
- Set of metric Allen keys with ball ends
- Crosshead screwdriver
- Disposable latex/rubber gloves
- Clean cloths
- Hairnet and/or beard net (food grade products only)
- Sterile shoe covers (food grade products only)



WARNING: To prevent any potential personal injury, ALWAYS unplug the FACF 3500® from the electrical outlet when removing and replacing parts.

Instructions

Note: Wear latex/rubber gloves (and appropriate food grade attire if applicable) during this process.

Remove Parts

1. Remove the Capsule Hoppers, Capsule Magazines, the Powder Hopper, the Auger, and the Tamping Disk station.
 - 1.1 Note: Please refer to the remove and replace Tooling instructions on page 46 for further information.
2. Take apart the Capsule Magazines.
 - 2.1 Note: Please refer to the remove and replace Capsule Holding Pins instructions on page 67 for further information.
3. Clean away any debris from inside the Capsule Magazines' tracks with a wire pipe cleaner.
4. Vacuum any excess powder from the bottom of the Tamping Turret and sanitize.



Clean the Parts

5. Take one of the parts removed from the machine and clean it with a cloth.
6. Ensure that the part is dry and set it aside.
7. Repeat steps 5-6 until all parts are clean.



Clean the External Area

8. Spray the FACF 3500® external area with the sanitizer, particularly in the location of the Capsule Die Segments, Capsule Magazines, and Tamping Turret.



9. Sanitize the FACF® external area with a clean cloth.

Cleaning Schedule Matrix

Part	After Installing Machine	After Every Use	Before Every Use	Inbetween Products That Present A Cross Contamination Risk	Weekly	Monthly	Before Placing In Storage	After Removing From Storage
Capsule Hopper	Wet clean and re-lubricate if specified in lubrication schedule	Dry clean and re-lubricate if specified in lubrication schedule	Dry clean and re-lubricate if specified in lubrication schedule	Wet clean and re-lubricate if specified in lubrication schedule	Dry clean and re-lubricate if specified in lubrication schedule	Wet clean and re-lubricate if specified in lubrication schedule	Dry clean and re-lubricate if specified in lubrication schedule	Wet clean and re-lubricate if specified in lubrication schedule
Powder Hopper	Wet clean and re-lubricate if specified in lubrication schedule	Wet clean and re-lubricate if specified in lubrication schedule	Wet clean and re-lubricate if specified in lubrication schedule	Wet clean and re-lubricate if specified in lubrication schedule	Wet clean and re-lubricate if specified in lubrication schedule	Wet clean and re-lubricate if specified in lubrication schedule	Wet clean and re-lubricate if specified in lubrication schedule	Wet clean and re-lubricate if specified in lubrication schedule
Base	Wet clean and re-lubricate if specified in lubrication schedule	Dry clean and re-lubricate if specified in lubrication schedule	Dry clean and re-lubricate if specified in lubrication schedule	Wet clean and re-lubricate if specified in lubrication schedule	Dry clean and re-lubricate if specified in lubrication schedule	Wet clean and re-lubricate if specified in lubrication schedule	Dry clean and re-lubricate if specified in lubrication schedule	Wet clean and re-lubricate if specified in lubrication schedule
Upper and Lower Sections of Capsule Closing Tooling	Wet clean and re-lubricate if specified in lubrication schedule	Wet clean and re-lubricate if specified in lubrication schedule	Wet clean and re-lubricate if specified in lubrication schedule	Wet clean and re-lubricate if specified in lubrication schedule	Wet clean and re-lubricate if specified in lubrication schedule	Wet clean and re-lubricate if specified in lubrication schedule	Wet clean and re-lubricate if specified in lubrication schedule	Wet clean and re-lubricate if specified in lubrication schedule
Capsule Magazine and Teeth	Wet clean and re-lubricate if specified in lubrication schedule	Dry clean and re-lubricate if specified in lubrication schedule	Dry clean and re-lubricate if specified in lubrication schedule	Wet clean and re-lubricate if specified in lubrication schedule	Wet clean and re-lubricate if specified in lubrication schedule	Wet clean and re-lubricate if specified in lubrication schedule	Dry clean and re-lubricate if specified in lubrication schedule	Wet clean and re-lubricate if specified in lubrication schedule
Tamping Turret and Stations	Wet clean and re-lubricate if specified in lubrication schedule	Dry clean with cloth	Wet clean and re-lubricate if specified in lubrication schedule	Wet clean and re-lubricate if specified in lubrication schedule	Dry clean with cloth	Wet clean and re-lubricate if specified in lubrication schedule	Dry clean with cloth	Wet clean and re-lubricate if specified in lubrication schedule

Cleaning Level Key

Level 1 - Remove powder
Level 2 - Dry clean with cloth
Level 3 - Dry clean and re-lubricate if specified in lubrication schedule
Level 4 - Wet clean and re-lubricate if specified in lubrication schedule
Remove from machine - Take part out of machine and clean if required. Store it correctly or install back into machine.
Install into machine - Install part into the machine and make sure that it has been cleaned. If needed, lubricate to the level required.
Clean on/in machine - Clean the part while in the machine and do not remove it. Make sure that all contact surfaces are clean to the level required.

This cleaning matrix is intended as a guide only and is not an exhaustive list. All cleaning schedules will need to be adapted to the industry and product, following industry regulations and the material safety data sheets that come with specific products. Please check with your Food Safety Manager/Department, Quality Control Manager/Department, or other relevant internal departments at your company before using.



Storing the FACF 3500®

After its thorough cleaning, the FACF 3500® needs to be stored in the proper conditions. It is important to store it in an environment in which the machine is safe from rusting. The FACF 3500®'s high traction areas and the Tooling need to be lubricated separately before you store them.

Tools and Materials Needed

- Plastic wrapping to cover machine
- Container(s) for Tooling (if in storage for more than a week)
- Lubricant/grease (NSF approved lubricant if machine has a high chance of contact with the food or drug product)
- Disposable latex/rubber gloves (for food grade products and to protect hands from lubricant)
- Hairnet and/or beard net (food grade products only)
- Sterile shoe covers (food grade products only)

Instructions

Note: Wear latex/rubber gloves (and appropriate food grade attire if applicable) during this process.

Lubricating the Tooling

If you are not using the machine for more than a week, store the Tooling in containers and cover it with lubricant to prevent rust formation. If not, simply lubricate each part of the Tooling and re-insert it back into the machine.

Lubricating the Grease Points and High-Traction Parts

1. Apply one layer of grease onto the work surface of the cams and rollers.
 - 1.1 Note: To see drawings of lubrication point locations, please refer to the Lubrication Schedule on page 42.
2. Apply lubrication oil to joint bearings, sealing bearings, and sliding guides.
3. Grease the ball bearings, needle bearings, and linear bearings.
4. Check the driving chains' tightness and apply lubricant.
5. Replenish the oil of the main driving and feeder decelerators.
6. Replenish the oil of the Main Turret and Tamping Section transfer cases.

Environmental Conditions

It is important that the environment in which you operate and store the FACF® has the appropriate temperature and relative humidity levels. These two environmental factors can potentially cause the machine to rust and/or cause the capsules to have a lower quality. The table below shows the acceptable temperature and relative humidity levels:

Machine	Temperature		Humidity
	°C	°F	
FACF 3500®	15-30	59-86	40-60% RH

Appendix

Glossary

Term	Definition
API/Active Pharmaceutical Ingredient	Any substance or mixture of substances used that is an active ingredient in the drug product.
Capsule Closing Plate	Plastic part with a chamfered edge that is secured over the Tooling. The filled capsule halves are sealed against the Capsule Closing Plate.
Capsule Magazine	The unit in which the capsules are inserted and oriented. It also feeds the capsule halves into the Tooling.
Capsule Sewing Section	Area of machine in which the capsules are oriented and fed into the Tooling.
Excipient	An inactive substance that serves as the vehicle or medium for a drug or other API.
Formulation	Powder mix of the excipient and the API that is used to fill capsules.
Megapascal (MPa)	The measure of force per unit area and defined as one newton per square meter.
Tamping Turret	Area of the machine in which powder slugs are formed and tamped into the capsule halves by the Tooling.
Tooling	Enables a fully automatic capsule filler to fill and seal capsules. The Tooling can be found in the Capsule Sewing Section, Tamping Turret, and Capsule Ejection Section.

Description of FACF[®] Range Parts

Filter Bag for Capsule Filler Vacuum Pump

The Filter Bag for the Capsule Filler Vacuum Pump catches dust and debris that come from the machine's operation. Order at lfacapsulefillers.com/filer-bag-capsule-filler-vacuum-pump

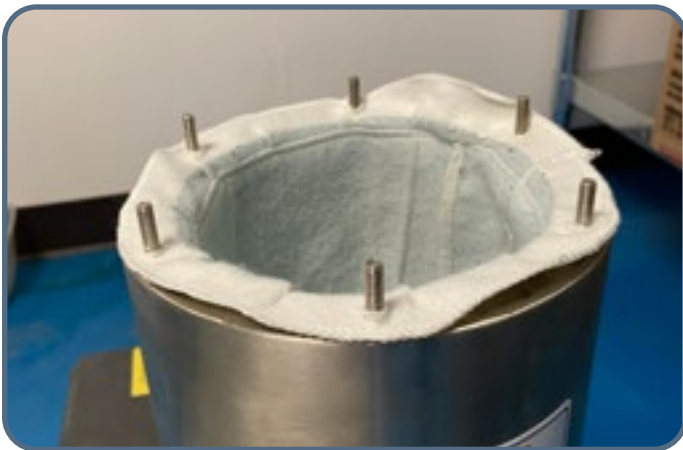

Vacuum Bag for TabVac Dust Vacuum

The Vacuum Bag for the TabVac catches the excess powder dust generated by the capsule filler. Order at lfacapsulefillers.com/vacuum-bag-tabvac-dust-vacuum



Tooling

The Tooling consists of the following:

- Capsule Orientation Teeth
- Tamping Pins
- Capsule Alignment Pins
- Dosing Alignment Pins
- Capsule Magazines
- Capsule Orientation Block
- Dosing Disk
- Capsule Segment Plates
- Capsule Sealing Pins
- Ejection Pin
- Alignment Pin (for Capsule Orientation Block and upper segment)
- Alignment Pin (for Ejection Pin and segments)

They all work as a set to fill the powder into capsules. Order at lfacapsulefillers.com/fac-range-plates-moulds-set



Capsule Suction Distribution Manifold

The Capsule Section Distribution Manifold is located in the Vacuum Plate Assembly. Order at lfacapsulefillers.com/capsule-suction-distribution-manifold-fac-range

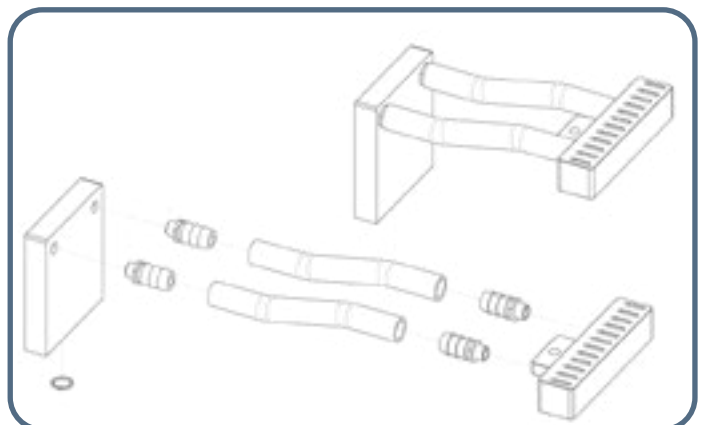





Food Grade Point of Contact Parts







Contact Part	Material
Upper Segment/Lower Segment	SUS 316
Dosing Disk	SUS 316
Tamping Pins	SUS 316
Conveying Plate	Alloy 6061-T6
Capsule Magazine Teeth	Alloy 6061-T6
Discharge Chute	SUS 304
Vacuum Feeder, Hopper, Scraping Plate	SUS 316L

Technical Specifications







Product	FACF® 3500
Maximum Capsules per Minute	3,500
Capsule Size	00 / 0 / 1 / 2 / 3 / 4 / 5
Filling Precision	±3%
Filling Bores	27
Decibels (dB)	≤78
Weight (kg /lbs)	1700 kg / 3,748 lbs
Power (kW)	7.5
Voltage (V)	208
3 Phase	Yes
Dimensions (mm / in)	1410 mm x 1144 mm x 2000 mm 55.5 in x 45.03 in x 78.7 in
Dimensions with suggested working clearance (mm / in)	2310 mm x 2044 mm x 2900 mm 90.9 in x 80.47 in x 114.17 in
Floor Loading Limit (Static)	26.8 kN/m ²





Toolbox Contents

	Part Name	Specifications	Quantity	Photo
1	Toolbox		1	
2	Clamp	32 x 44	3	
3	Wrench for Dosing Disk		1	
4	Crosshead Screwdriver		1	
5	Flathead Screwdriver		1	

	Part Name	Specifications	Quantity	Photo
6	Wrench Set	6 mm - 24 mm	1	
7	Double-End Wrench		3	
8	Allen Key Set		1	
9	Feeler Gauge	0.02 - 1 mm	1	
10	Capsule Removal Needle		4	
11	Brush		4	

	Part Name	Specifications	Quantity	Photo
12	Upper Mold Frame Dismount Tool		2	
13	Spring Sheet	6 - 15	1	
14	Allen Key	12	1	
15	Outer Hexagonal Bolts	M6 x 16	16	
16	Outer Hexagonal Bolts	M8 x 25	6	
17	Outer Hexagonal Bolts	M8 x 35	6	

	Part Name	Specifications	Quantity	Photo
18	Feeding Hopper		1	
19	Anchor and Bolt		4	
20	Dosing Disk Alignment Pins - FACF Range		2	
21	Capsule Segment Alignment Pins - FACF Range		2	
22	Capsule Magazine Alignment Pins - FACF Range		2	
23	Capsule Sealing Pins - FACF Range		24	

	Part Name	Specifications	Quantity	Photo
24	Capsule Ejection Pin - FACF Range		24	
25	Tamping Pins - FACF Range		24	
26	Capsule Sealing Alignment Pins - FACF Range		2	
27	T-Shaped Wrench		1	
28	Capsule Closing Pin		24	
29	Shaft	3-34	2	
30	New Vertical Guiding Rod	3-41	4	
31	Handwheel	30-02	1	
32	Vacuum Pump Tube		1	

FACF 3500[©] Bearings List

SN	Spare Part Name	Part Code	Qty	Unit Price (USD)
1	Needle bearing SZ NA4904	005020037	11 pieces	10.00
2	Deep groove ball bearing 608ZZ	005020038	10 pieces	8.00
3	Linear bearing SDE20Y	005020048	8 pieces	14.00
4	Deep groove ball bearing 6203ZZ	005020158	2 pieces	10.00
5	Cam bearing CF- 12B(30P)	005020184	5 pieces	14.00
6	Cam bearing CF18B	005020188	1 piece	25.00
7	Ball bearing SA208	005020226	3 pieces	14.00
8	Pin end bearing	005020237	5 pieces	6.00
9	Pin end bearing	005020238	5 pieces	6.00
10	Needle bearing SZ NA6904	005020282	1 piece	25.00
11	Cam bearing NAST 10ZZ	005020176	2 pieces	18.00
12	Linear bearing SDE25Y	005020049	4 pieces	22.00
13	Linear bearing 10Y	005020046	80 pieces	12.50
14	Deep groove ball bearing 6000ZZ	005020286	10 pieces	12.00
15	Cam bearing CF- 6B(16P)	005020191	10 pieces	12.50
16	Linear bearing SDE12Y	005020045	8 pieces	11.00
17	Deep groove ball bearing 6004Z	005020069	2 pieces	8.00
18	Bearing	005020299	1 piece	8.00



Maintenance Checklist

Before Operation	
<input type="checkbox"/>	Visually inspect the fully automatic capsule filler and the parts.
<input type="checkbox"/>	Ensure all nuts and bolts are tight.
<input type="checkbox"/>	Visually inspect grease points and re-grease where necessary.
<input type="checkbox"/>	Run the machine at a slow speed to ensure that everything is operating correctly.
<input type="checkbox"/>	Visually inspect electrical wires for any damage.
During Operation	
<input type="checkbox"/>	Tune the fully automatic capsule filler until the capsule fill and weight are correct.
<input type="checkbox"/>	Listen for irregular knocking or clicking sounds. If heard, stop operation, dislodge any stuck capsules from the machine, adjust the Capsule Holding Pins, and lubricate the machine.
<input type="checkbox"/>	Watch for buildup of powder on the Auger inside the Powder Hopper. If occurring, either (a) make mix more granular, (b) check the Auger for damage, or (c) clear the buildup.
<input type="checkbox"/>	Occasionally check the Motor's temperature. If it starts to overheat, turn off the machine, let it cool down, and grease it to ensure smooth operation.
<input type="checkbox"/>	Ensure that the Hoppers do not run out of powder and capsules.
<input type="checkbox"/>	Weigh five or ten sample capsules to ensure the desired weight and fill are being met.
<input type="checkbox"/>	Check to see that the Emergency Stop properly works.
After Operation	
<input type="checkbox"/>	Unplug machine and remove all excess powder with a bagless vacuum.
<input type="checkbox"/>	Clean the Capsule Hopper, the Powder Hopper, the Capsule Magazine and teeth, the Tooling, and the Auger.
<input type="checkbox"/>	Wipe down the other surfaces with a damp cloth.
<input type="checkbox"/>	Lubricate all grease points.
<input type="checkbox"/>	Store Tooling in a container with a small amount of grease.

Diagrams

FACF 3500® Floor Plan

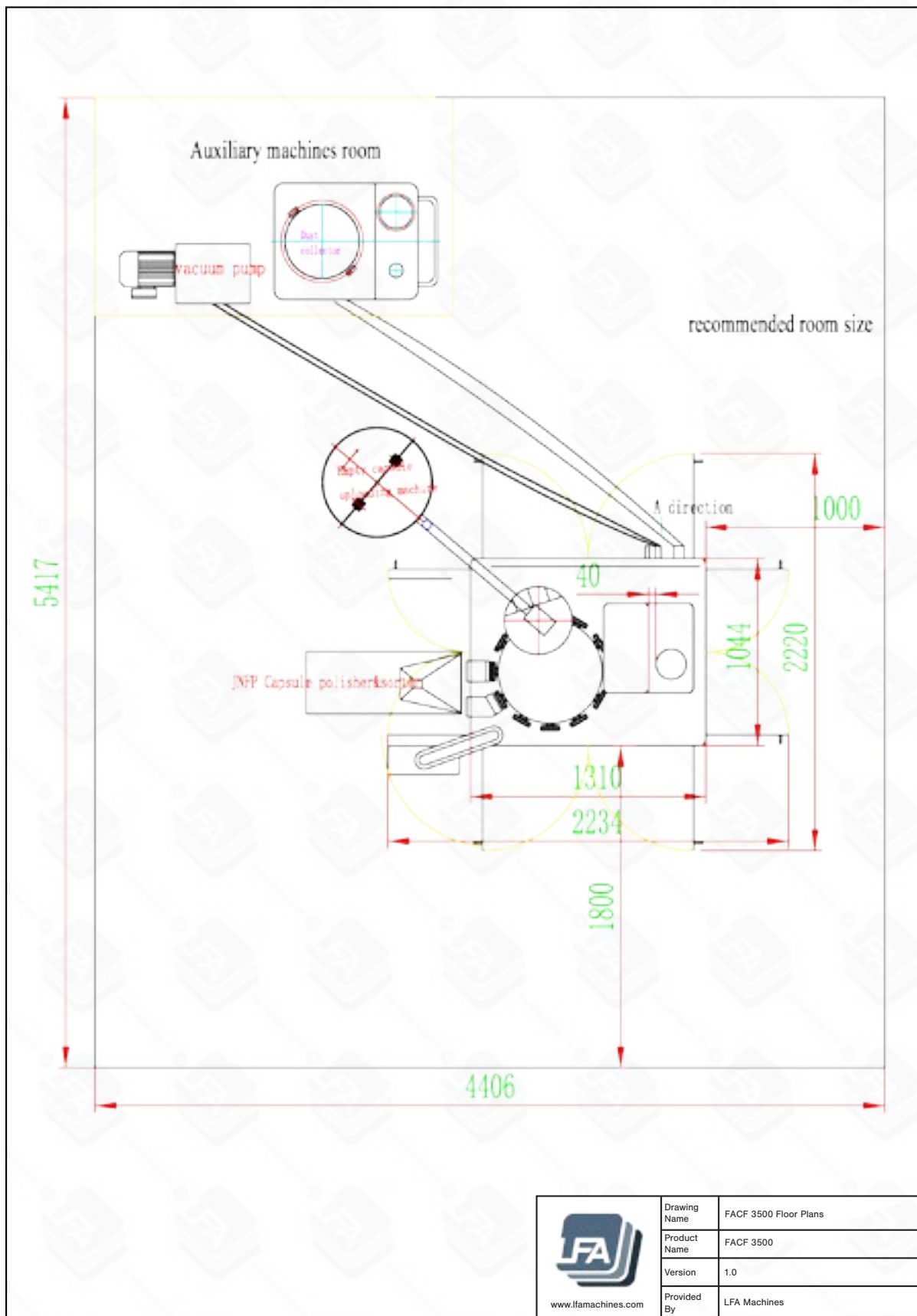

FACF 3500® Schematics

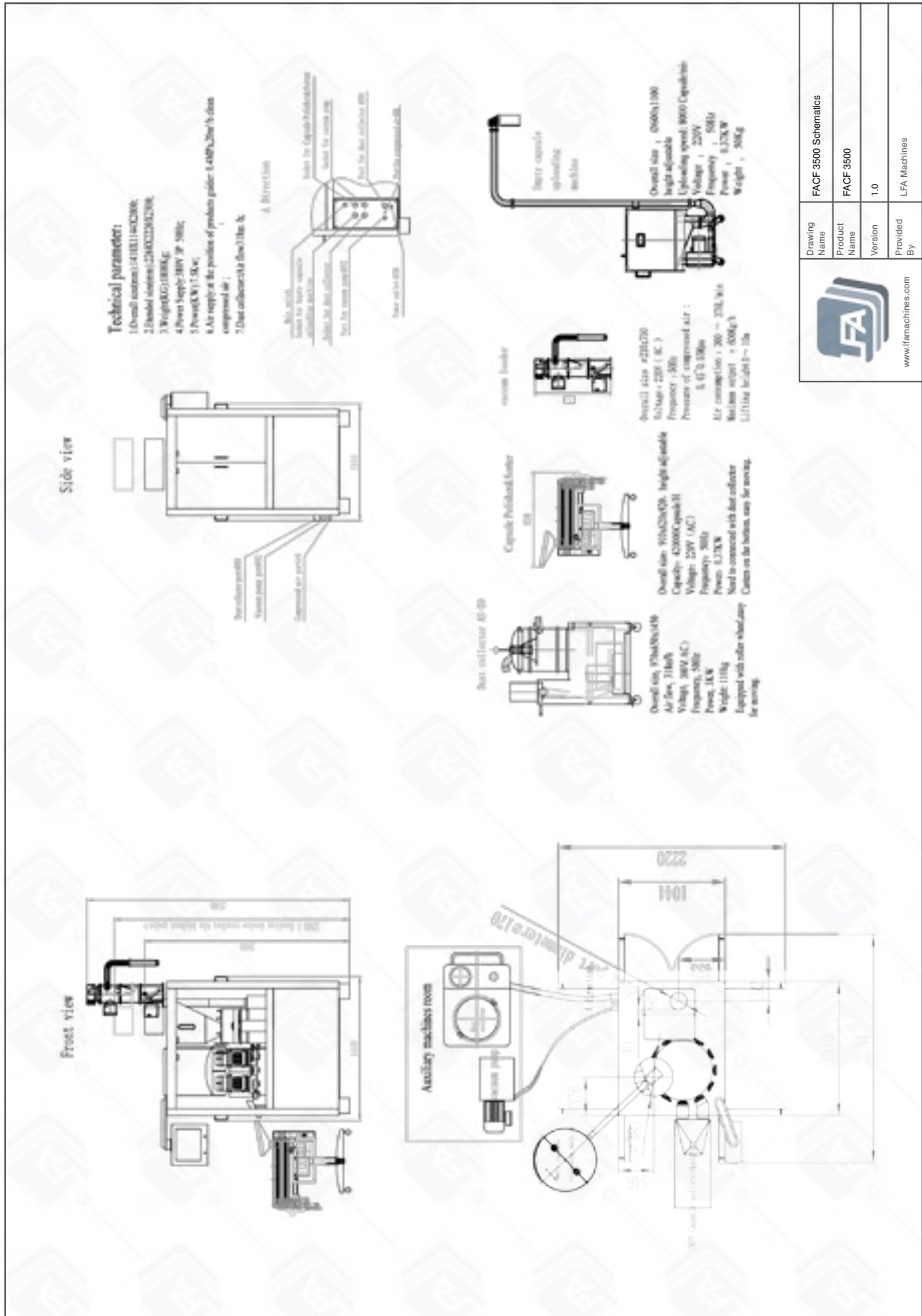

 www.lfamachines.com	Drawing Name	FACF 3500 Schematics
	Product Name	FACF 3500
	Version	1.0
	Provided By	LFA Machines

FACF 3500® Wiring Diagram 1

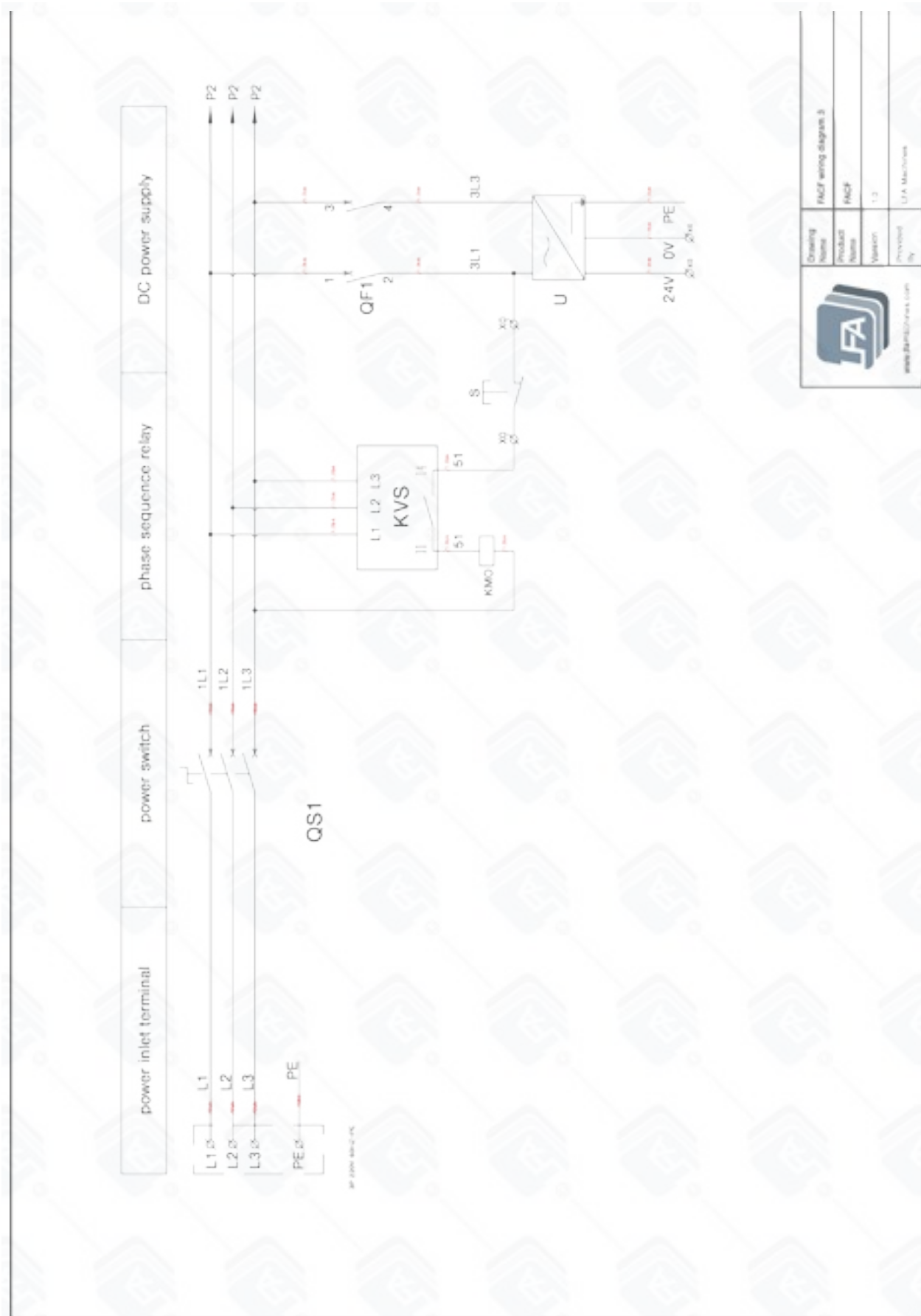

	www.lfa.com
Drawing Name: FACF wiring diagram 3 Product Name: FACF Version: 1.3 Provided By: LFA Machines	

FACF 3500® Wiring Diagram 2

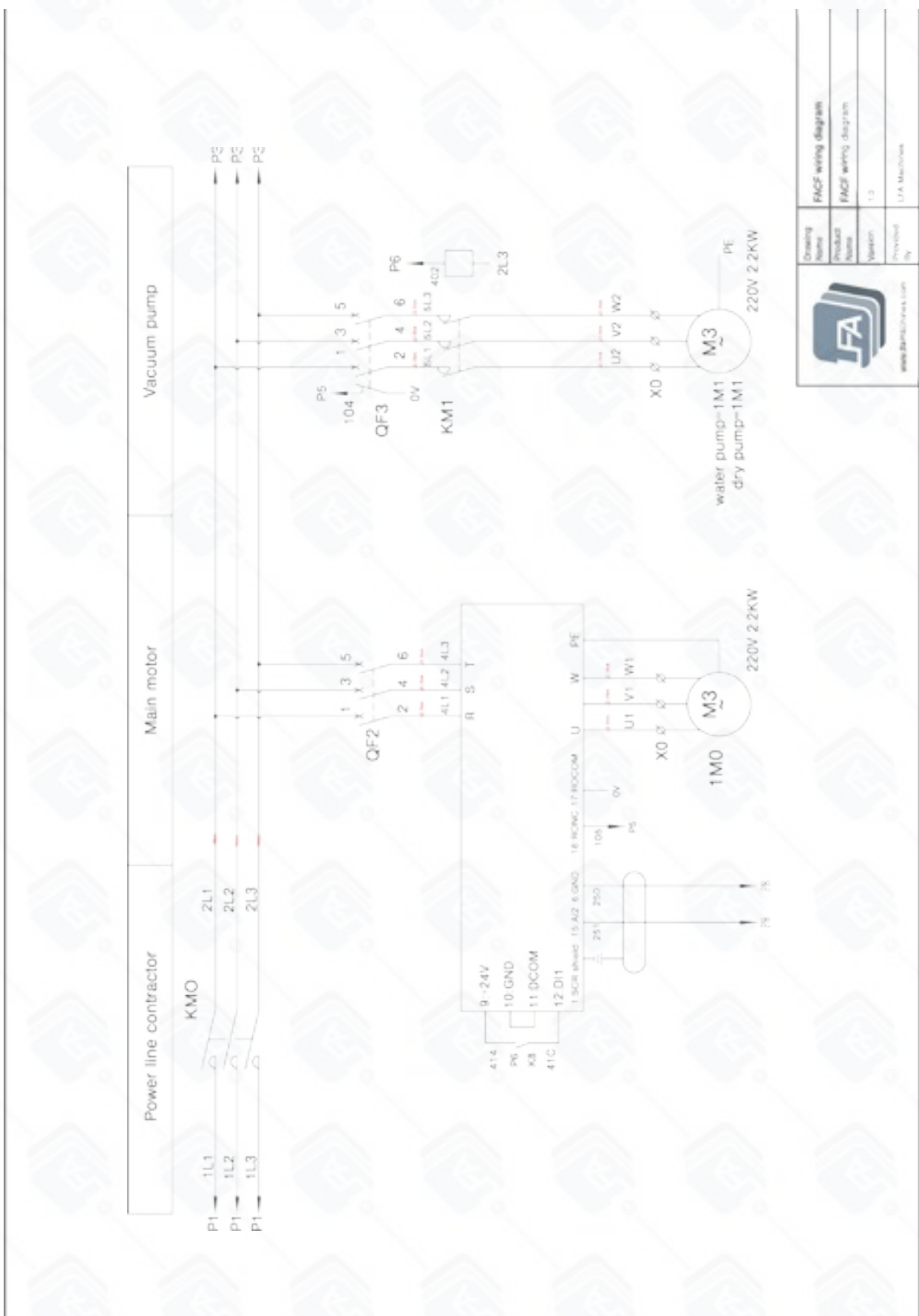

	Drawing Name	FACF wiring diagram
	Product Name	FACF wiring diagram
	Version	1.2
	Provided By	LFA Machines

FACF 3500® Wiring Diagram 3

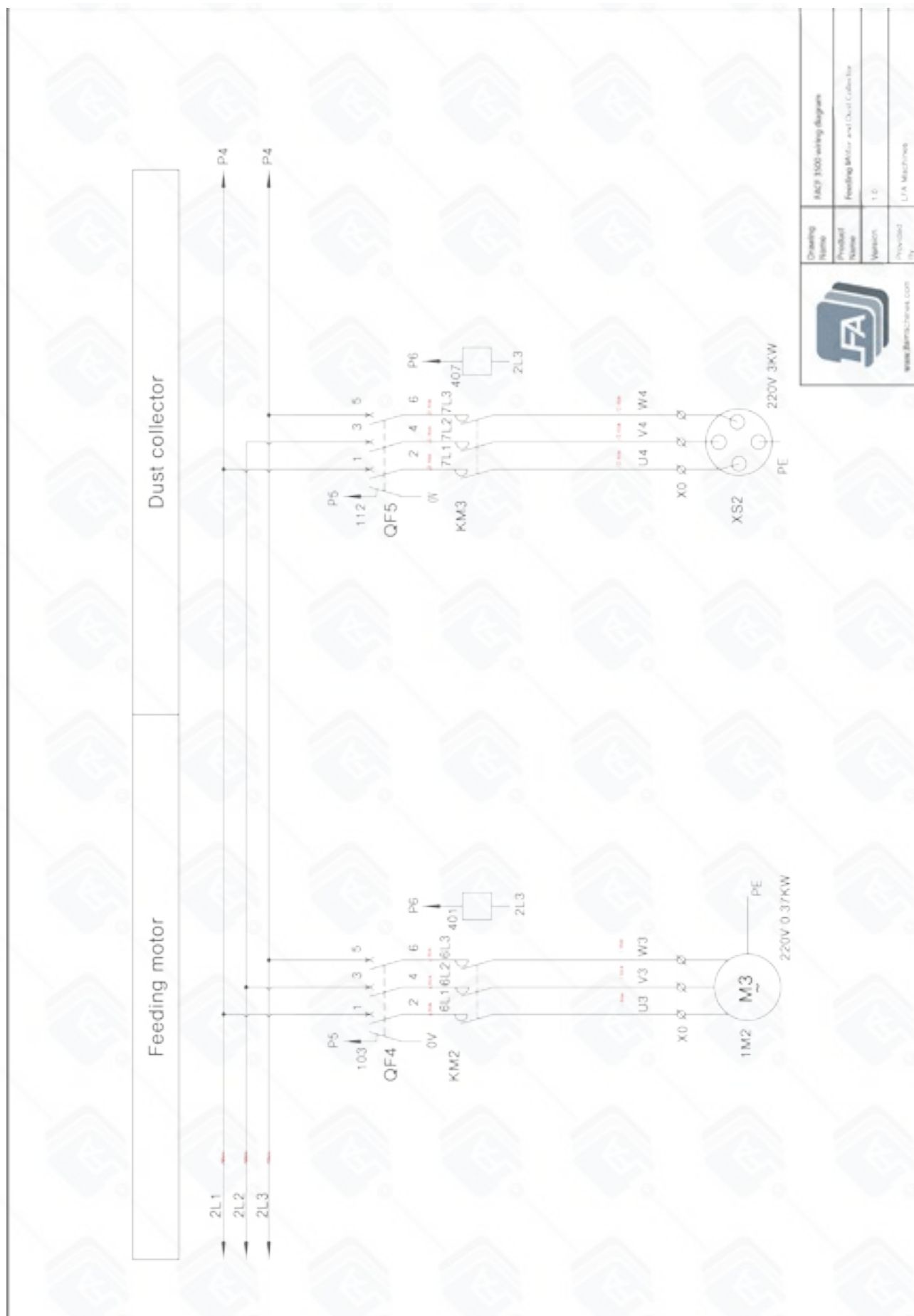

	Drawing Name	FACF 3500 wiring diagram
	Product Name	Feeding Motor and Dust Collector
	Version	1.0
	Provided by	LFA Machines

FACF 3500® Wiring Diagram 4

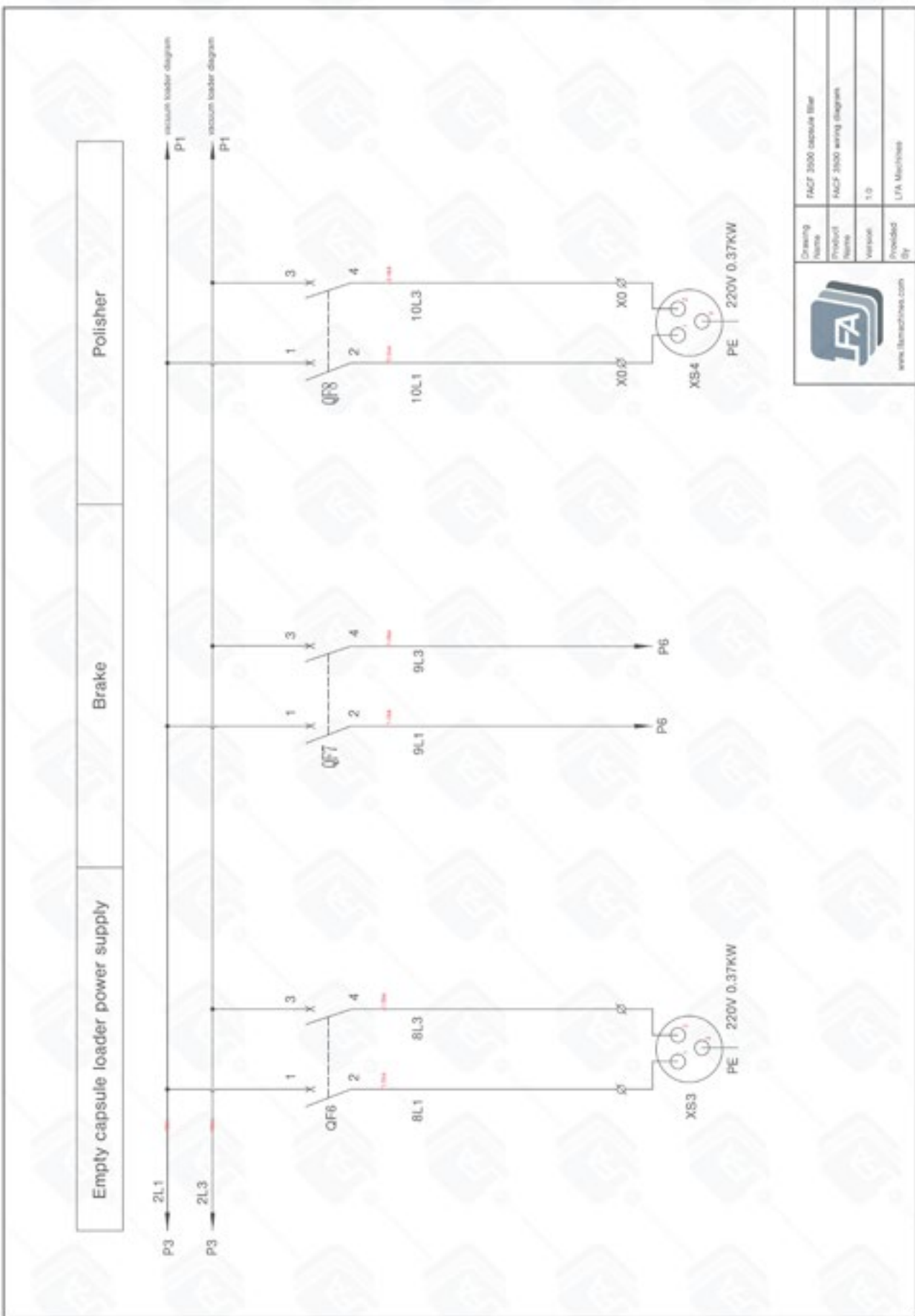

FACF 3500® Wiring Diagram 5

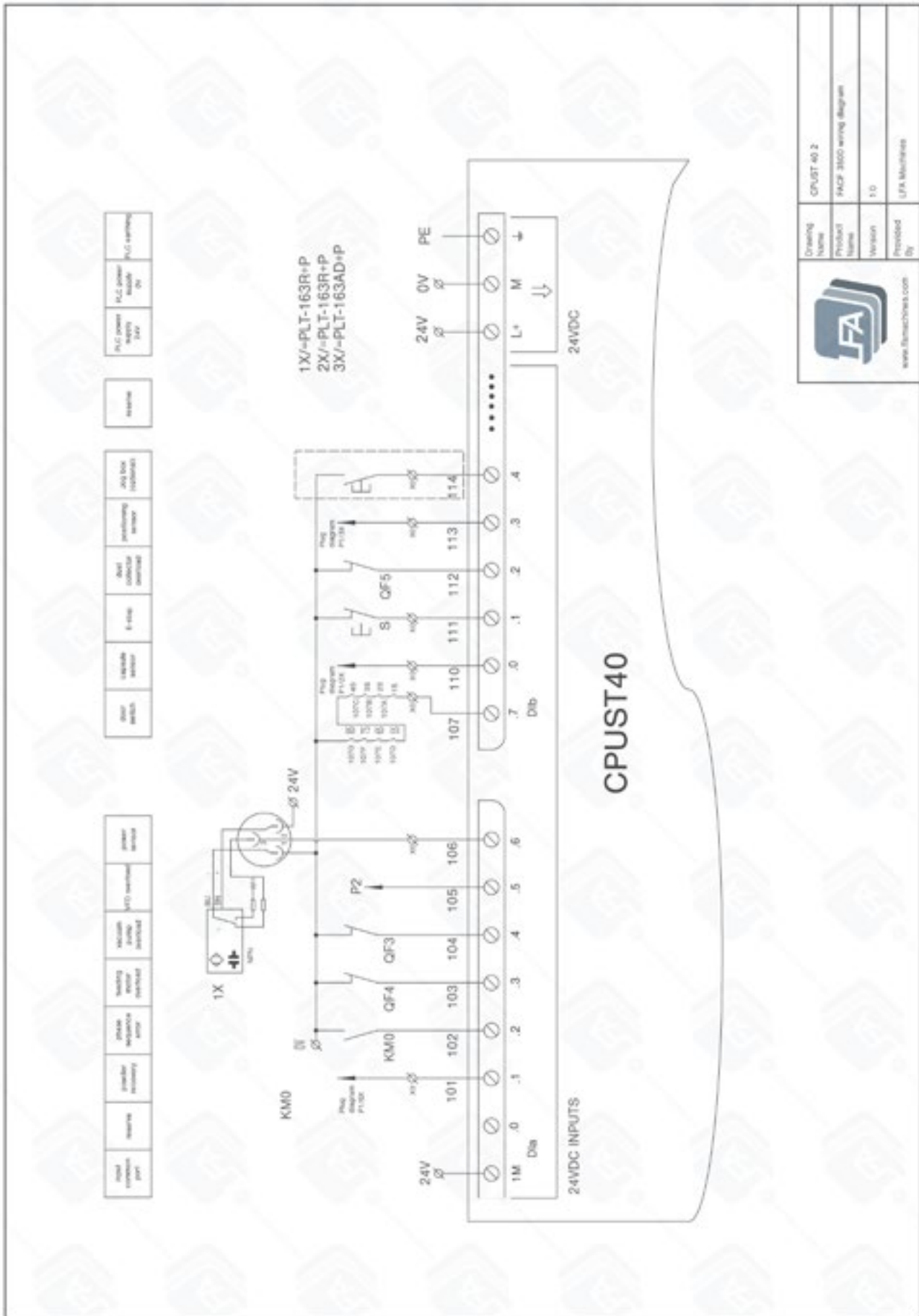

	Drawing Name	CPUST 40 2
	Product Name	FACF 3500 wiring diagram
	Version	1.0
	Provided By	LFA Machines
	www.lfamachines.com	

FACF 3500® Wiring Diagram 6



	Drawing Name	CPUST40 wiring diagram
	Product Name	FACF 3500 wiring diagram
	Version	1.0
	Provided By	LFA Machines

FACF 3500® Wiring Diagram 7

PLC power supply +24V	PLC power supply 0V	PLC earthing
--------------------------	------------------------	--------------



 www.lfa-machines.com	Drawing Name	PLC Power Supply
	Product Name	FACF 3500 wiring Diagram
	Version	1.0
	Provided By	LFA Machines

FACF 3500® Wiring Diagram 8

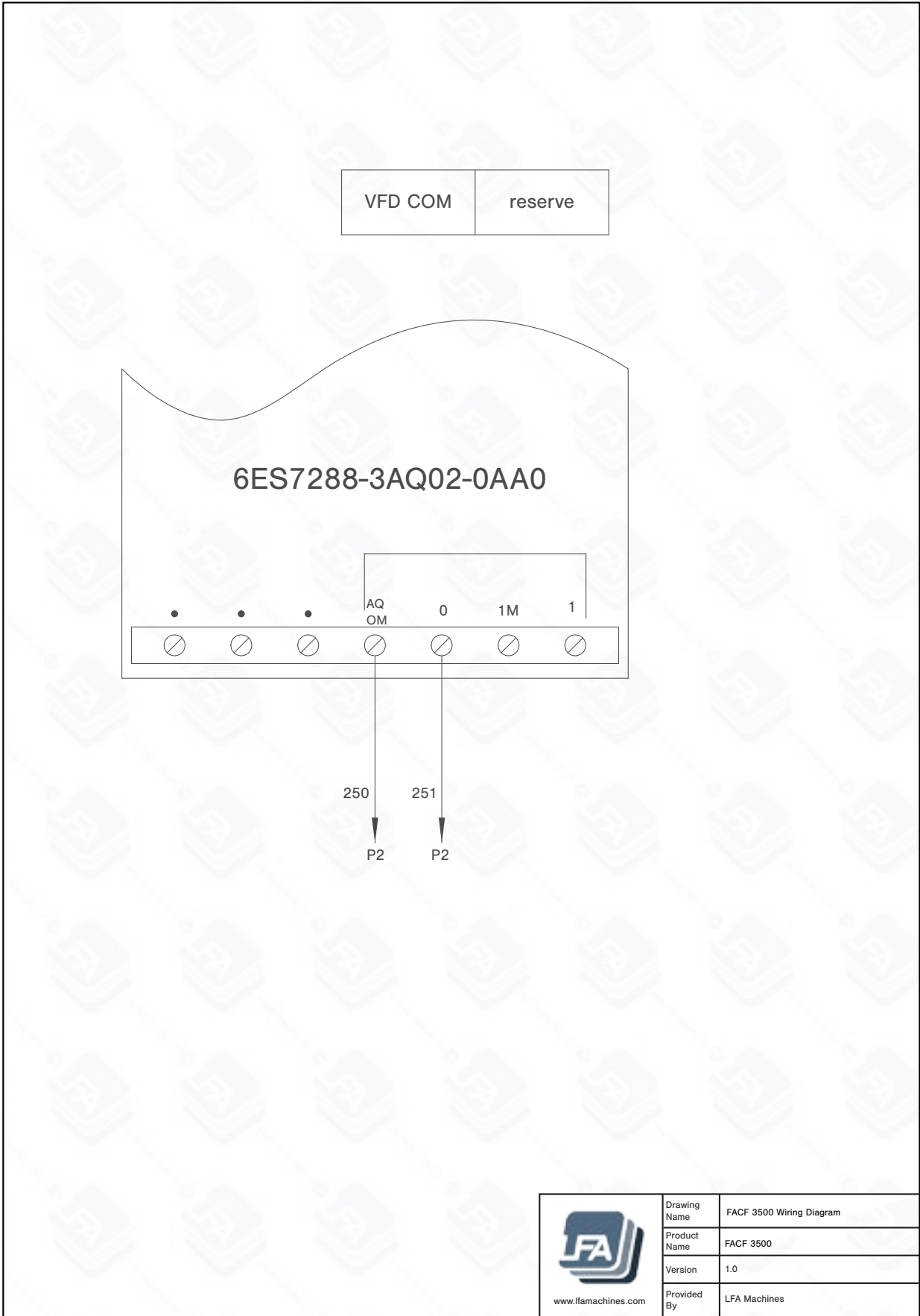

FACF 3500® Wiring Diagram 9

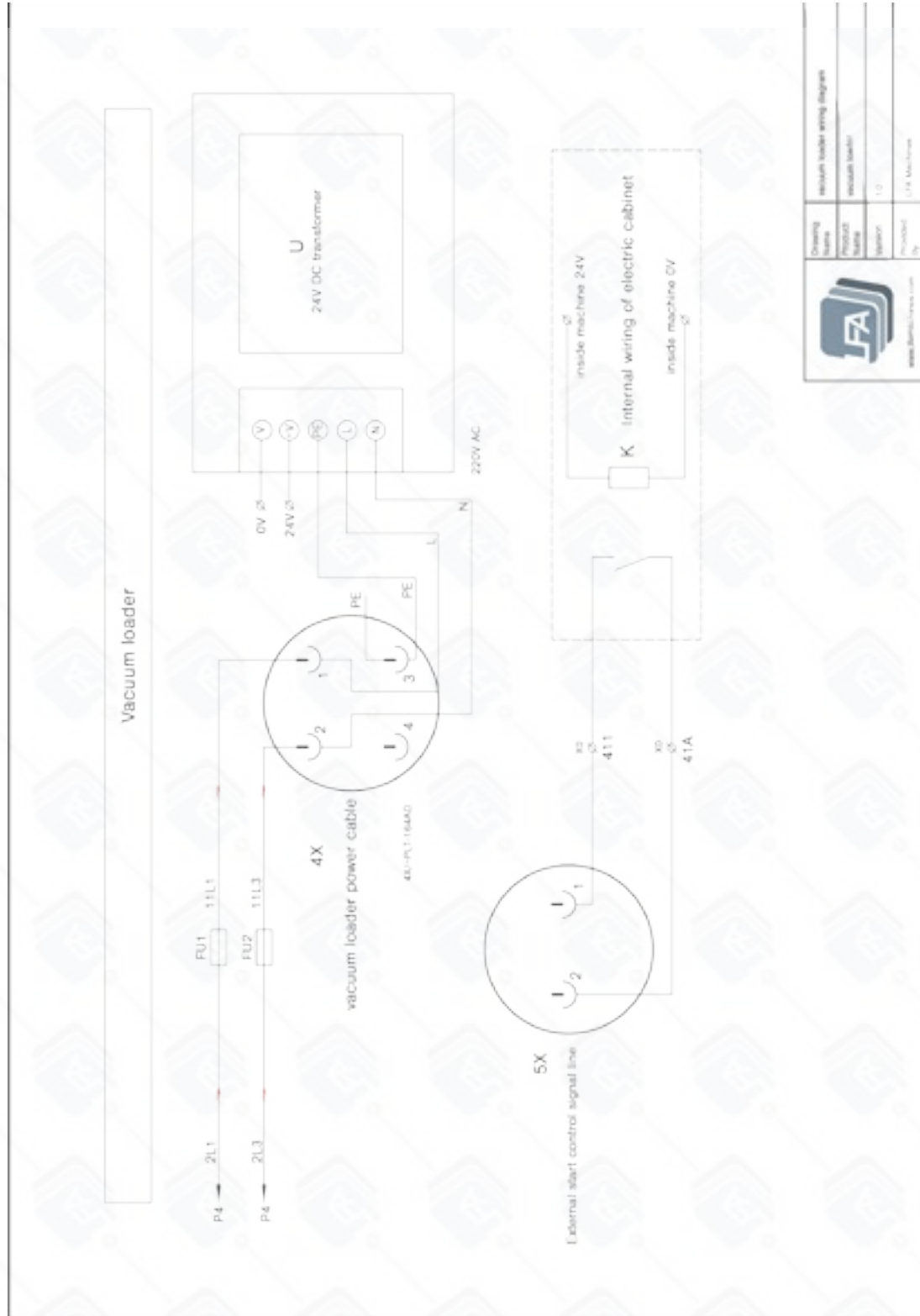

FACF 3500® Wiring Diagram 10

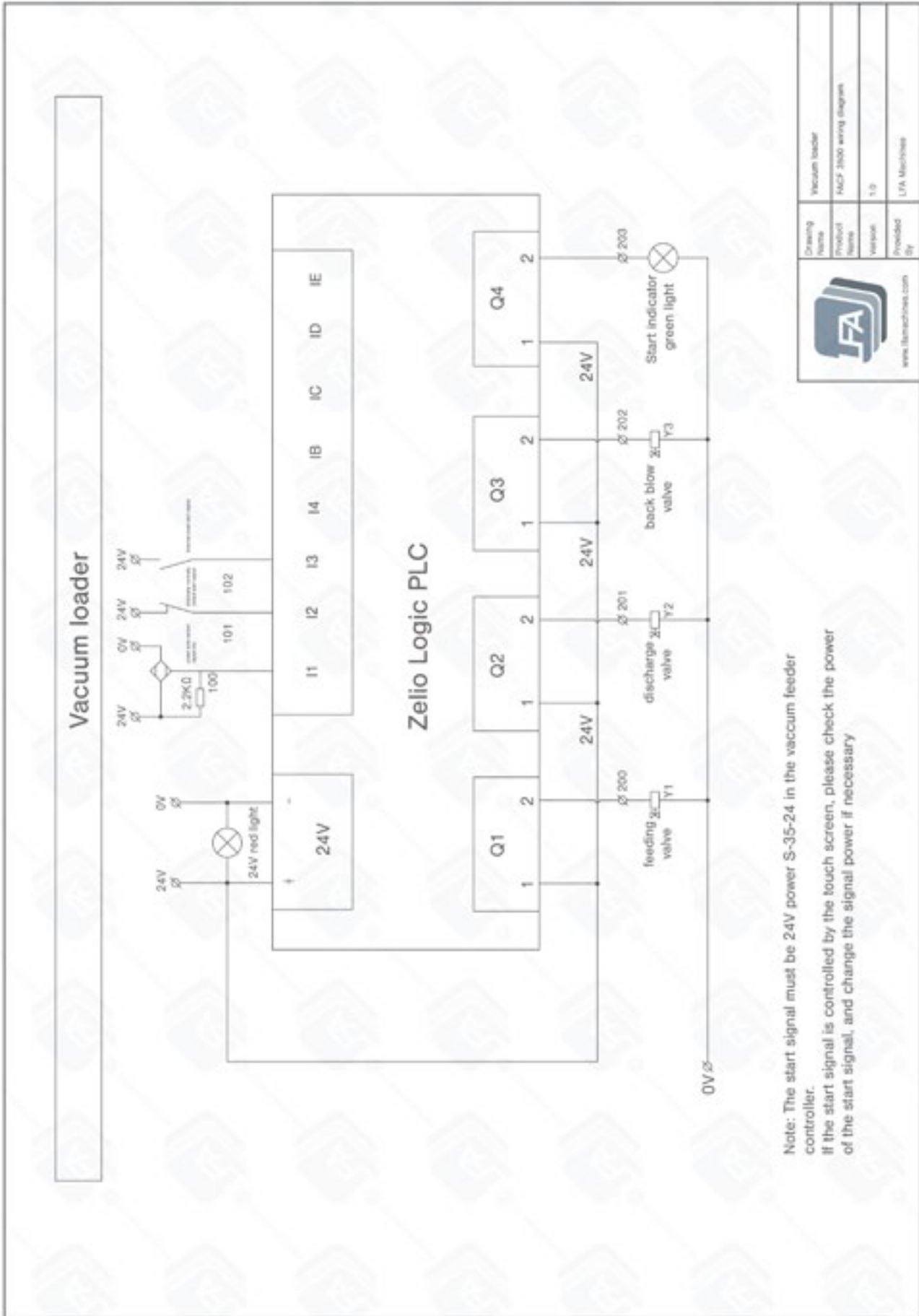

FACF 3500® Wiring Diagram 11

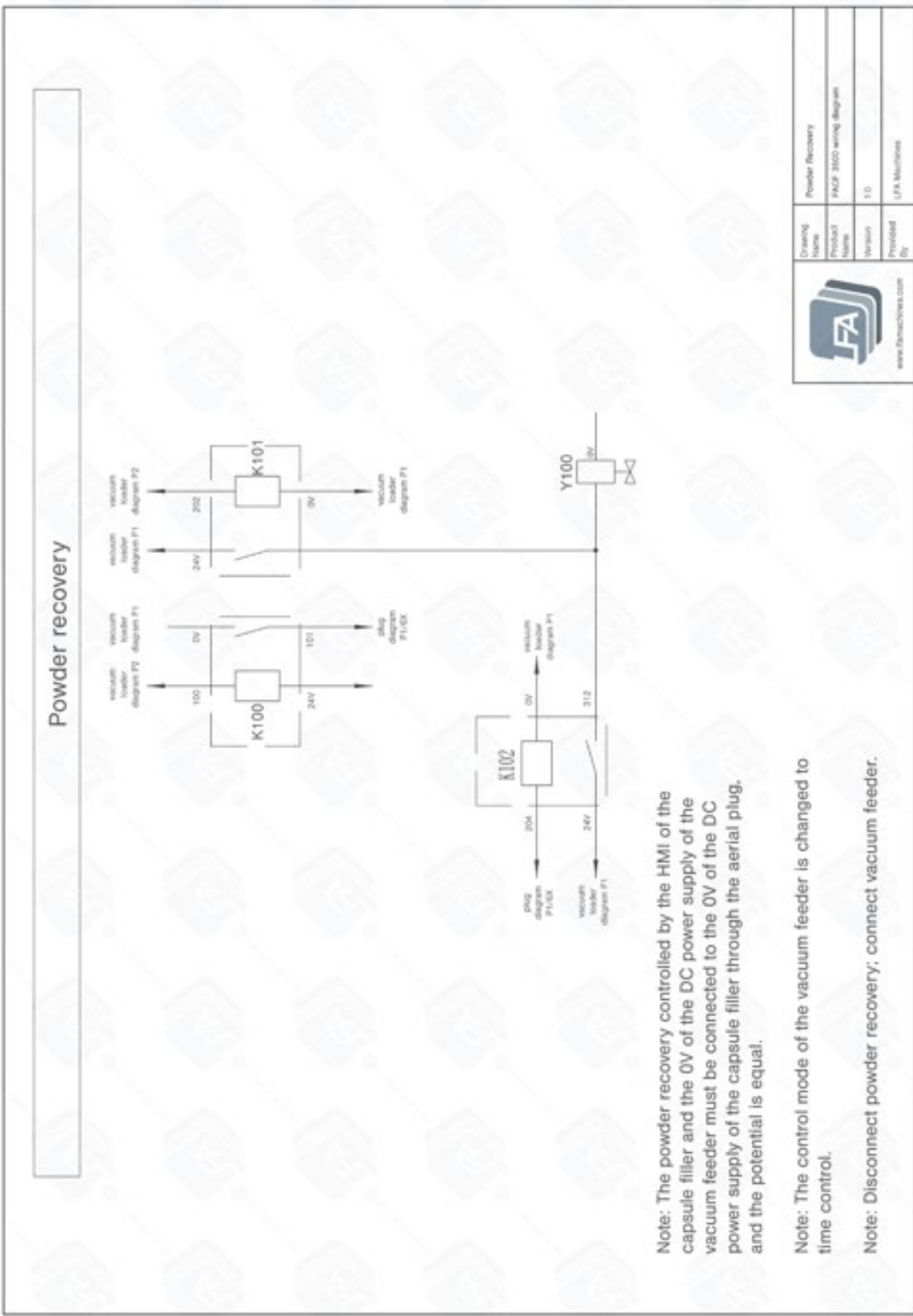

 www.lfa-machines.com	Drawing Name	Powder Recovery
	Product Name	FACF 3500 wiring diagram
	Version	1.0
	Provided By	LFA Machines

FACF 3500® Wiring Diagram 13

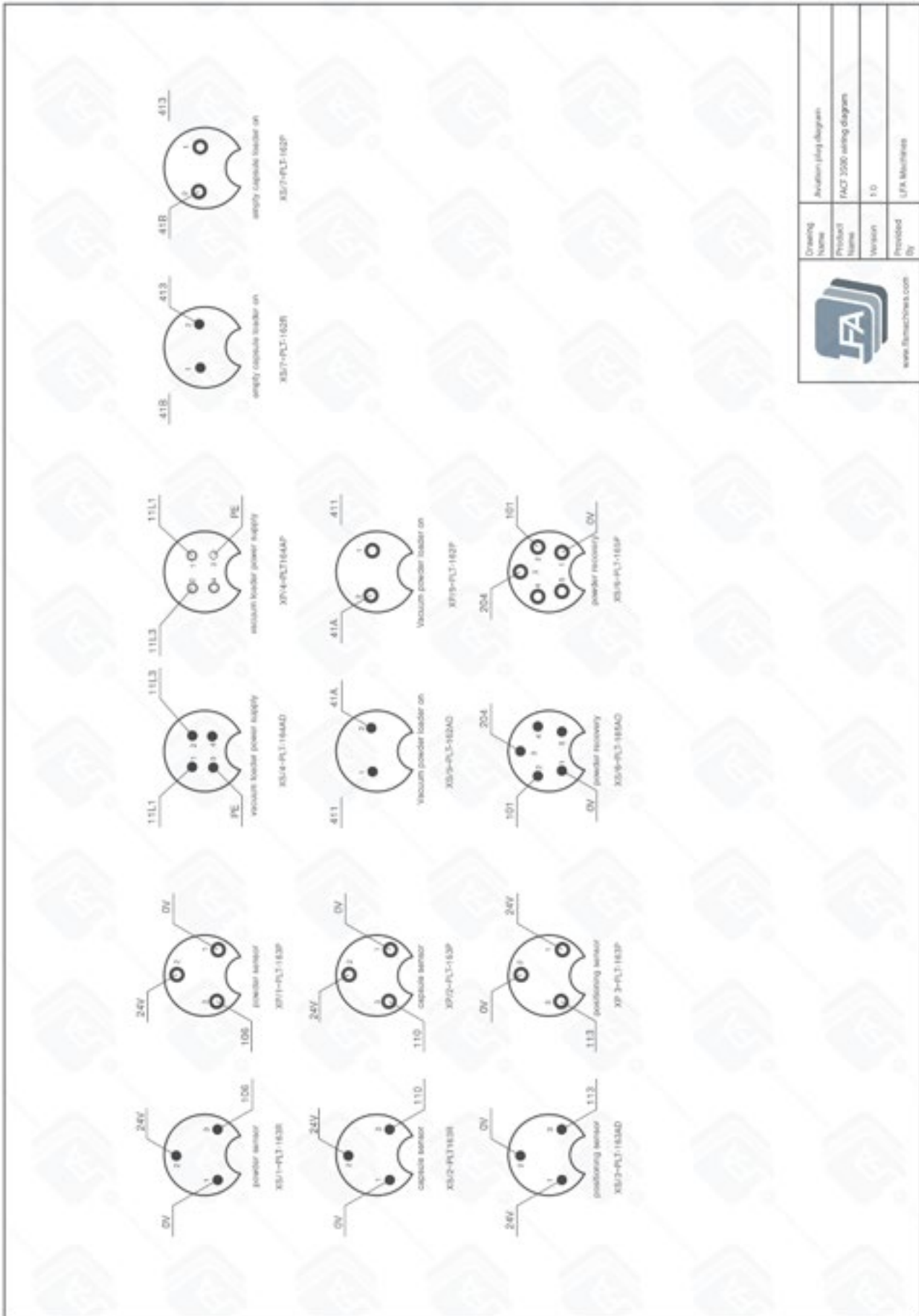

 www.lfa-machines.com	Drawing Name	Injection jing diagram
	Product Name	FACF 3500 wiring diagram
	Version	1.0
	Provided By	LFA Machines

FACF 3500® Wiring Diagram 14

Cantilever Configuration



Cantilever plug



 www.lfa-machines.com	Drawing Name	Cantilever Configuration
	Product Name	Cantilever Configuration
Version	1.0	
Prepared By	LFA Machines	

FACF 3500® Wiring Diagram 15

Part list

No.	symbol	description	model	No.	symbol	description	model	No.	symbol	description	model
1	CPUST40	PLC	6ES72881ST40AA0	14	KM1	vacuum pump contractor	3RT6026-1AN20				
2	VF	main VFD	ACS395-03E-13A3-2	15	KM2	feeding motor contractor	3RT6016-1AN21				
3	HMI	touch screen	6AV6648-0CE11-3AX0	16	KM3	dust collector contractor	3RT6026-1AN20				
4	OSI	power switch	P1-32	17	U	DC power	LRB-50-24				
5	QF1	DC power air switch	5SL62047CC	18	KVB	phase sequence protector	3UG4512-1AR20				
6	QF2	main motor air switch	5SL63167CC	19	K	Relay motor relay	CR64204LD-200028CC				
7	QF3	vacuum pump switch	3RV6011-4AA10	20	X0	terminal board	ZDU1, 5/ZDU2, 5/ZDU6				
8	QF4	feeding motor switch	3RV6011-1CA10	21	H1	motor	HRB-PS30-DC24V				
9	QF5	dust collector switch	3RV6011-4AA10	22	X31	dry pump socket	5623				
10	QF6	filter air switch	5SL62167CC	23	X32	dust collector socket	5618				
11	QF7	brake air switch	5SL62047CC	24	X33	empty discharge bucket socket	5601				
12	QF8	polisher air switch	5SL62167CC	25	X34	poller socket	5601				
13	KMO	main circuit contractor	3RT6027-1AN20								



www.lfa-machines.com

Drawing Name	Part List	Product Name	EAD 1000 wiring Diagram
Version	1.0	Provided By	LFA Machines

FACF 3500® Wiring Diagram 16

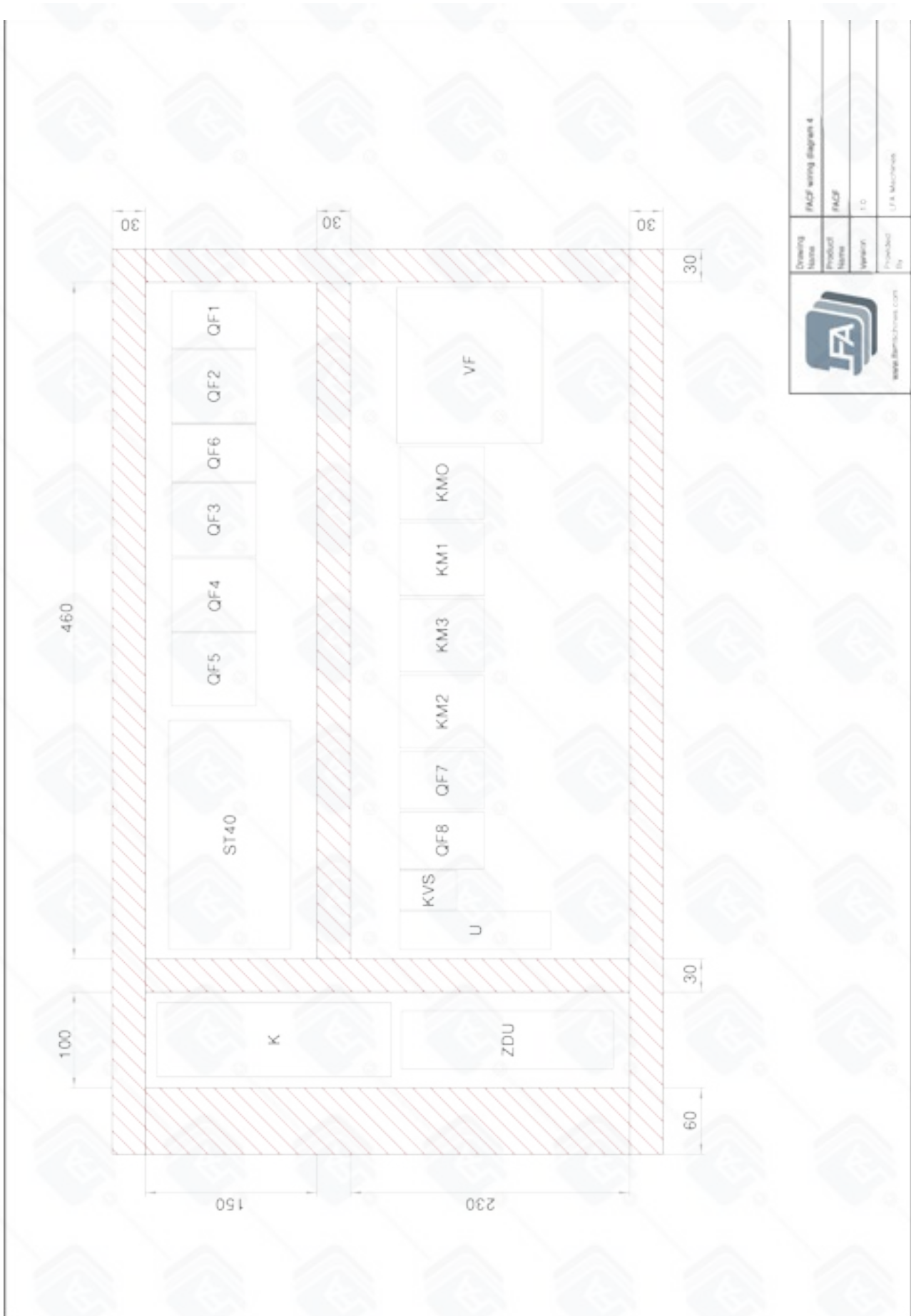

FACF 3500® Wiring Diagram 17

VFD Parameter Setting

9904	Vector speed
9905	Motor rated voltage
9906	Motor rated current
9907	Motor rated frequency
9908	Motor rated frequency
9909	Motor rated power
1001	DI1 (starting method)
1003	Forward (forward & reverse)
1103	AI2 (select the externally given signal source)
2101	Automatic 2 (starting method)
2102	Free stop
2202	5 (acceleration time)
2203	2 (Deceleration time)
1105	2000 (Max. setting speed)
2002	2000 (Max. speed)

 www.lfamachines.com	Drawing Name	VFD Parameter Setting
	Product Name	VFD Parameter Setting
	Version	1.0
	Provided By	LFA Machines



Resources

Helpful Links

Warranty

For information regarding the warranty policy of the FACP® range and other products, please visit lfacapsulefillers.com/warranty

LFA Machines Website

In order to aid you in your capsule production, LFA Machines maintains a website that offers a breadth of useful information about the FACP® range and other capsule fillers. You also have access to online tools such as the Capsule Size Chart and our regularly published articles that cover a whole range of topics about capsule fillers and capsule production.

Visit our homepage at lfacapsulefillers.com

To create a free member's account, follow this link: lfacapsulefillers.com/customer/account/create

Contact Us

USA

LFA Machines DFW, LLC
6601 Will Rogers Blvd
Fort Worth, TX 76140
+1 (682) 312 0034
support.usa@lfamachines.com
Monday-Friday
8AM-4:30PM UTC (Central)

Germany

LFA Machines Düsseldorf GmbH
Business Parc Am Trippelsberg 92
Düsseldorf, North-Rhine
Westphalia 40589
+41 21188250223
verkauf@lfamachines.com

UK

LFA Machines Oxford Ltd
Unit 4B Rowood Estate
Murdock Road
Bicester, Oxfordshire OX26 4PP
+44 01869 250234
support.uk@lfamachines.com
Monday-Friday
9AM-5PM GMT

Taiwan

LFA Machines Taiwan Ltd
7F-5, No. 2, Sec. 2 Taiwan Blvd
West District, Taichung City 403
Taiwan
+886 422031790
support.asia@lfamachines.com
Monday-Friday
9AM-5PM Taipei Standard Time

LFA Machines YouTube Channel

Our YouTube videos provide you an opportunity to see demonstrations of how to use our fully automatic capsule fillers, common troubleshooting tips, and other capsule fillers and mixers. We regularly upload videos to give you a visual aid that will hopefully support you in your capsule production efforts. To watch our videos, visit youtube.com/lfamachines

LFA Machines Social Media

Social media is a great way to keep yourself updated on new developments and exciting things happening at LFA Machines. The list below contains our current social media pages:

Twitter: [@lfatabletpress](https://twitter.com/lfatabletpress)

Facebook: facebook.com/lfamachines

LinkedIn: linkedin.com/company/lfa-machines/



LFA Machines

Copyright © 2024 by LFA Machines

www.lfamachines.com

United States

6601 Will Rogers Blvd
Fort Worth
Texas
United States
76140

United Kingdom

Unit 4B
Murdock Road
Bicester
Oxfordshire
United Kingdom
OX26 4PP

Germany

Business Parc Am
Trippelsberg 92
Düsseldorf
Germany
40589

Taiwan

7F.-5, No. 2, Sec. 2
Taiwan Blvd., West Dist.,
Taichung City 403,
Taiwan